

SD5 Series  
Spectra II™ and  
Spectra Lite™ Dome

Installation/  
Operation Manual

C1487M-C (7/99)



Pelco • 300 W. Pontiac Way, Clovis • CA 93612-5699 USA • Pelco Online @ <http://www.pelco.com>  
In North America and Canada: Tel (800) 289-9100 or FAX (800) 289-9150 • DataFAX (800) 289-9108  
International Customers: Tel (1-559) 292-1981 or FAX (1-559) 348-1120 • DataFAX (1-559) 292-0435

# CONTENTS

<u>Section</u>	<u>Page</u>
GENERAL .....	4
IMPORTANT SAFEGUARDS AND WARNINGS .....	4
IN-CEILING MODELS .....	5
PENDANT MODELS .....	6
DESCRIPTION .....	7
MODELS .....	7
SPECTRA II™ PENDANT COMPONENTS .....	7
SPECTRA II™ IN-CEILING COMPONENTS .....	7
SPECTRA LITE™ PENDANT COMPONENTS .....	8
SPECTRA LITE™ IN-CEILING COMPONENTS .....	8
INSTALLATION FOR IN-CEILING MODELS .....	8
CEILING AND BACK BOX PREPARATION .....	8
HARD CEILING .....	8
SUSPENDED CEILING .....	9
WIRING .....	10
BACK BOX INSTALLATION .....	12
BACK BOX CONNECTIONS .....	13
DOME DRIVE .....	15
LOWER DOME .....	21
INSTALLATION FOR PENDANT MODELS .....	22
PENDANT-MOUNT INSTALLATION .....	22
SURFACE-MOUNT INSTALLATION .....	23
OPERATION .....	23
POWER-UP DISPLAY .....	24
PAN AND TILT FUNCTIONS .....	24
AUTO FLIP .....	24
SCAN SPEED .....	24
ZOOM .....	25
SPECTRA II™ ZOOM .....	25
SPECTRA LITE™ ZOOM .....	25
PRESET FUNCTIONS .....	25
RANDOM, FRAME, AND AUTO SCANNING .....	26
ZONES .....	26
PATTERNS .....	26
ALARMS .....	26
AUXILIARY OUTPUTS .....	27
PARK .....	27
PROGRAMMING THE SPECTRA II™ AND SPECTRA LITE™ .....	28
MAIN MENU ACCESS .....	29
BACKLIGHT COMPENSATION .....	29
ZOOM LIMIT .....	30
RESET CAMERA .....	30
GAIN/AGC .....	31
AUTO IRIS .....	32
SHUTTER SPEED .....	33
AUTO-FOCUS MODE .....	34
SHARPNESS .....	34
WHITE BALANCE (COLOR CAMERAS ONLY) .....	35
LINE SYNCHRONIZATION .....	35
POWER-UP MODE .....	36
AUX MODE .....	37
ALARM RESUME .....	37
ALARM DWELL .....	38
ALARM PRIORITY .....	38
ALARM PATTERN .....	39
ZONE BLANK .....	39
AUTO FLIP .....	40
PROPORTIONAL PAN .....	40

<u>Section</u>	<u>Page</u>
LIMIT STOPS .....	41
PARK TIME MINUTES .....	42
SCAN SPEED .....	42
PATTERN LENGTH .....	42
TROUBLESHOOTING .....	43
BACK BOX ELECTRONIC ASSEMBLY REMOVAL .....	45
MAINTENANCE .....	45
DOME CLEANING .....	45
SERVICE MANUAL .....	45
SPECIFICATIONS .....	46
REGULATORY NOTICES .....	50
WARRANTY AND RETURN INFORMATION .....	50

### LIST OF ILLUSTRATIONS

<u>Figure</u>	<u>Page</u>
1 In-Ceiling Components .....	5
2 Back Box Parts .....	5
3 Pendant Components .....	6
4 Compass Tool .....	8
5 Conduit Fitting Installation .....	8
6 Installing Back Box .....	9
7 Fastening Back Box .....	9
8 Wiring Diagram for Spectra II™ .....	10
9 Wiring Diagram for Spectra Lite™ .....	11
10 Interconnect Door .....	12
11 Transformer .....	13
12 Interconnect Circuit Board Electrical Connections for Spectra II™ .....	13
13 Interconnect Circuit Board Electrical Connections for Spectra Lite™ .....	14
14 Switch Locations .....	15
15 Lower Dome Installation, In-Ceiling Models .....	21
16 Lower Dome Installation, Pendant Models .....	22
17 Backlight .....	29
18 SD5 Series Dimension Drawing .....	47

### LIST OF TABLES

<u>Table</u>	<u>Page</u>
A Video Coaxial Cable Wiring Distances .....	11
B 24 VAC Wiring Distances .....	12
C Switch Settings for SW1 .....	15
D Switch Settings for SW2 – P-Type Control .....	16
E Switch Settings for SW2 – D-Type Control .....	17

## GENERAL

### IMPORTANT SAFEGUARDS AND WARNINGS

Prior to installation and use of this product, the following WARNINGS should be observed.

1. Installation and servicing should only be done by qualified service personnel and conform to all local codes.
2. Unless the unit is specifically marked as a NEMA Type 3, 3R, 3S, 4, 4X, 6, or 6P enclosure, it is designed for indoor use only and it must not be installed where exposed to rain and moisture.
3. Only use replacement parts recommended by Pelco.
4. After replacement/repair of this unit's electrical components, conduct a resistance measurement between line and exposed parts to verify the exposed parts have not been connected to line circuitry.
5. The installation method and materials should be capable of supporting four times the weight of the enclosure, pan/tilt, camera and lens combination.

The product and/or manual may bear the following marks:



This symbol indicates that dangerous voltage constituting a risk of electric shock is present within this unit.



This symbol indicates that there are important operating and maintenance instructions in the literature accompanying this unit.

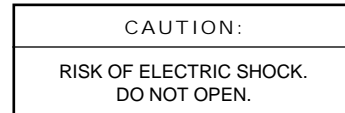

Please thoroughly familiarize yourself with the information in this manual prior to installation and operation.

### MEASURES DE SECURITE IMPORTANTES

Avant d'installer ou d'utiliser ce produit, les mesures de sécurité suivantes sont à prendre:

1. Toute installation et réparation devraient être entreprises par un technicien qualifié et conformes au codes locaux.
2. A moins que cet équipement indique avoir un boîtier agréé NEMA de type 3, 3R, 3S, 4, 4X, 6 ou 6P, il est uniquement conçu pour utilisation intérieure et ne peut donc pas être en contact de pluie ou d'humidité.
3. Utiliser seulement les pièces de rechanges recommandées par Pelco.
4. Après toute installation ou réparation de la partie électrique de ce produit, une résistance entre le courant et la partie exposée devrait être installée afin de vérifier que la partie électrique n'aie pas été en contact d'un court circuit.
5. L'installation entreprise et le matériel utilisé devraient supporter quatre fois le poids du boîtier, de la tourelle, de la caméra, et de la lentille.

Ce produit et/ou le manuel pourrait inclure les symboles suivants:



Ce symbol indique qu'un voltage dangereux pouvant provoquer un choc électrique est présent dans cette unité.



Ce symbol indique qu'il y a des mesures d'installation et d'entretien importantes inclus dans le manuel de cet équipement.

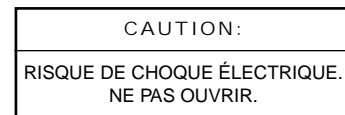

Nous vous prions de bien vous familiarisez avec le manuel avant d'entreprendre toute installation.

## IN-CEILING MODELS

The Spectra II™ dome and Spectra Lite™ dome shipping cartons contain three boxes, plus the C1487M-C system manual that covers everything in the system (back box, dome drive, and lower dome). Inspect each box to make sure all parts are present.

### Back Box

- 1 Back box
- 1 Parts bag (refer to Figure 2)
  - 1 Conduit fitting
  - 1 Safety chain bracket
  - 1 Lock nut
  - 1 Compass tool
  - 4 T-rail clip (clip, L-bracket, screw, lock washer and nut)
- 1 Installation/Operation Manual (C1488M-B)

### Dome Drive

- 1 Dome drive
- 1 Installation/Operation Manual (C1489M-A for Spectra II™ or C1498M-A for Spectra Lite™)

### Lower Dome

- 1 Acrylic lower dome with trim ring
- 1 Installation Instructions (C1457M-B)

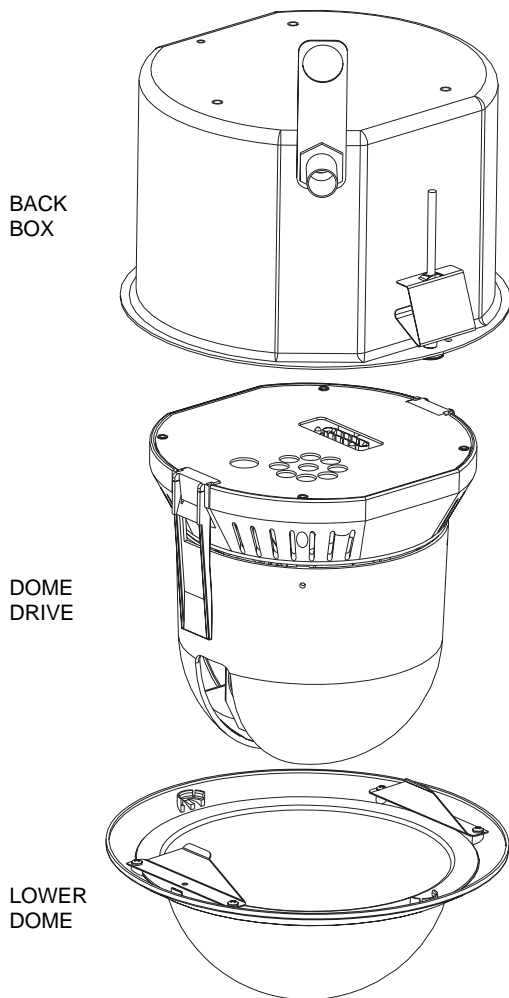

**Figure 1.** In-Ceiling Components

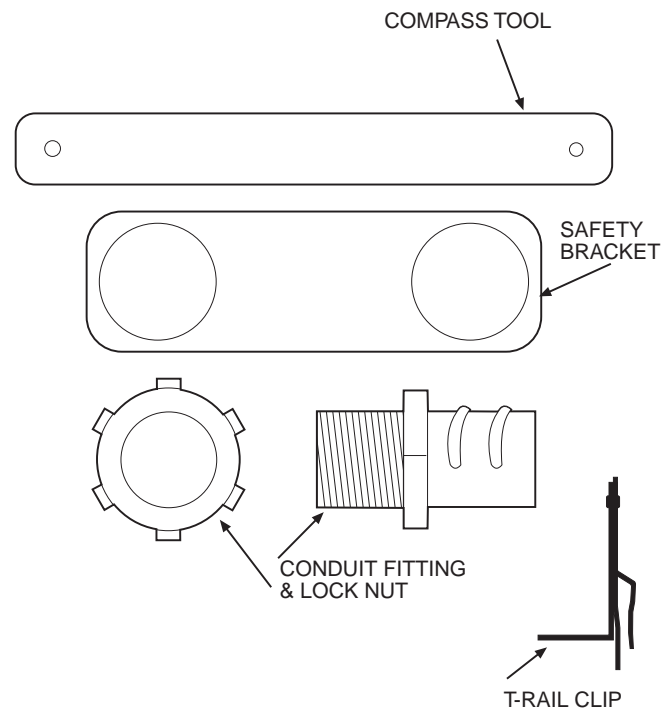

**Figure 2.** Back Box Parts

## PENDANT MODELS

The Spectra II™ dome and Spectra Lite™ dome shipping cartons contain three boxes, plus the C1487M-C system manual that covers everything in the system (back box, dome drive, and lower dome). Inspect each box to make sure all parts are present.

### Back Box

- 1 Back box
- 1 Tube of pipe sealant
- 1 Installation/Operation Manual (C1488M-B)

### Dome Drive

- 1 Dome drive
- 1 Installation/Operation Manual (C1489M-A for Spectra II™ or C1498M-A for Spectra Lite™)

### Lower Dome

- 1 Acrylic lower dome with trim ring
- 1 Parts bag
  - 1 O-ring
  - 1 O-ring lubricant
  - 2 Screw, 6-32 x 1/4" (black) or 6-32 x 5/16" (gray)
  - 1 Tube of Loctite®
- 1 Installation Instructions (C1457M-B)

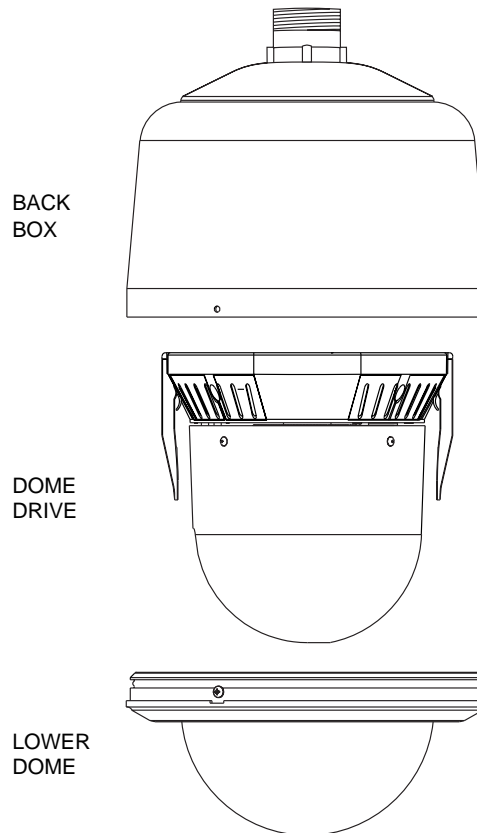

**Figure 3.** Pendant Components

## DESCRIPTION

Spectra II™ and Spectra Lite™ domes are capable of the following:

- 360° pan rotation
- +2 to -92° tilt
- preset positioning
- variable speed

The in-ceiling models can be installed in hard ceilings or standard 2' x 2' (61 cm x 61 cm) suspended ceilings. These models are for indoor installation only.

The pendant models can be installed indoors or outdoors. The outdoor models include a sun shield and heater. The heater allows operation in temperatures down to -60°F (-51°C).

An integral receiver has a switch to select the type of control. The receiver supports Coaxitron® and RS-422 control types.

The dome drive quickly disconnects from the back box for easy servicing or moving.

Spectra II™ models include either a high-resolution color or monochrome camera with a 16X optical, 8X electronic zoom lens for a total zoom ratio of 128X. Spectra Lite™ models include a preset focus color CCD camera with a 12X zoom lens.

Spectra II™ models include additional features—such as zones, patterns, alarms, auxiliary relays, and auto focus—that are not part of Spectra Lite™ models.

The Spectra II™ and Spectra Lite™ domes operate on 24 VAC.

## MODELS

Each Spectra II™ and Spectra Lite™ system consists of one each: back box, dome drive, and lower dome. Outdoor pendant systems include a sun shield and heater. Refer to components below (in-ceiling or pendant) to determine your system configuration.

### SPECTRA II™ PENDANT COMPONENTS

BB5A-PB	Black pendant-mount back box (CE, UL, cUL)
BB5A-PG	Light gray pendant-mount back box (CE, UL, cUL)
BB5A-PG-E	Same as BB5A-PG except includes heater and sun shield (CE, UL, cUL)
DD5AC	Dome drive with color camera/lens, NTSC standard (FCC, UL, cUL)
DD5AC-X	Dome drive with color camera/lens, PAL standard (CE)
DD5AM	Dome drive with monochrome camera/lens, EIA standard (FCC, UL, cUL)
DD5AM-X	Dome drive with monochrome camera/lens, CCIR standard (CE)
LD5PB-0	Smoked lower dome (1/2 f-stop of light loss) for black pendant-mount dome
LD5PB-1	Clear lower dome for black pendant-mount dome
LD5PB-2	Chrome lower dome (2 f-stops of light loss) for black pendant-mount dome
LD5PB-3	Gold lower dome (2 f-stops of light loss) for black pendant-mount dome
LD5PG-0	Smoked lower dome (1/2 f-stop of light loss) for light gray pendant-mount dome
LD5PG-1	Clear lower dome for light gray pendant-mount dome
LD5PG-2	Chrome lower dome (2 f-stops of light loss) for light gray pendant-mount dome
LD5PG-3	Gold lower dome (2 f-stops of light loss) for light gray pendant-mount dome
LD5PG-E0	Same as LD5PG-0 except includes heater
LD5PG-E1	Same as LD5PG-1 except includes heater
LD5PG-E2	Same as LD5PG-2 except includes heater
LD5PG-E3	Same as LD5PG-3 except includes heater

### SPECTRA II™ IN-CEILING COMPONENTS

BB5A-F	Indoor back box for flush mounting in a ceiling (CE, UL, cUL)
DD5AC	Dome drive with color camera/lens, NTSC standard (FCC, UL, cUL)
DD5AC-X	Dome drive with color camera/lens, PAL standard (CE)
DD5AM	Dome drive with monochrome camera/lens, EIA standard (FCC, UL, cUL)
DD5AM-X	Dome drive with monochrome camera/lens, CCIR standard (CE)
LD5F-0	Smoked lower dome (1/2 f-stop of light loss)
LD5F-1	Clear lower dome
LD5F-2	Chrome lower dome (2 f-stops of light loss)
LD5F-3	Gold lower dome (2 f-stops of light loss)

## SPECTRA LITE™ PENDANT COMPONENTS

BB5T-PB	Black pendant-mount back box (CE, UL, cUL)
BB5T-PG	Light gray pendant-mount back box (CE, UL, cUL)
BB5T-PG-E	Same as BB5T-PG except includes heater and sun shield (CE, UL, cUL)
DD5T-C	Dome drive with color camera and lens, NTSC standard (FCC, UL, cUL)
DD5T-C-X	Dome drive with color camera and lens, PAL standard (CE)
LD5PG-0	Smoked lower dome (1/2 f-stop of light loss) for light gray pendant-mount dome
LD5PG-1	Clear lower dome for light gray pendant-mount dome
LD5PG-2	Chrome lower dome (2 f-stops of light loss) for light gray pendant-mount dome
LD5PG-3	Gold lower dome (2 f-stops of light loss) for light gray pendant-mount dome
LD5PG-E0	Same as LD5PG-0 except includes heater
LD5PG-E1	Same as LD5PG-1 except includes heater

## SPECTRA LITE™ IN-CEILING COMPONENTS

BB5T-F	Indoor back box for flush mounting in a ceiling (CE, UL, cUL)
DD5T-C	Dome drive with color camera and lens, NTSC standard (FCC, UL, cUL)
DD5T-C-X	Dome drive with color camera and lens, PAL standard (CE)
LD5F-0	Smoked lower dome (1/2 f-stop of light loss)
LD5F-1	Clear lower dome
LD5F-2	Chrome lower dome (2 f-stops of light loss)
LD5F-3	Gold lower dome (2 f-stops of light loss)

## INSTALLATION FOR IN-CEILING MODELS

To install the dome proceed through the steps in this section, beginning with the *Ceiling and Back Box Preparation* section.

### CEILING AND BACK BOX PREPARATION

*NOTE: Use the SCA1 (structural ceiling adapter) if additional support is required.*



**CAUTION:** Be careful not to cut outside of the line. If you do, you may not be able to install the back box. Also, the trim ring may not cover the hole.

#### HARD CEILING

1. Locate the center point where you want to drill a hole in the ceiling. (The ceiling tile cannot be thinner than 0.50 inch [1.27 cm] nor thicker than 1.75 inches [4.45 cm].)
2. Drill a hole in the ceiling using a 3/32-inch drill bit.
3. Remove the compass tool from the parts bag that came with the back box (refer to Figure 4). Press the stud of the compass tool into the hole in the ceiling. Insert a pencil in the hole in the other end of the compass and mark a circle on the ceiling.
4. Carefully cut the circle out of the ceiling.
5. Remove the conduit fitting, lock nut, and safety chain bracket from the parts bag and attach them to the back box as shown in Figure 5.

Proceed to the *Wiring* section.



**Figure 4.** Compass Tool

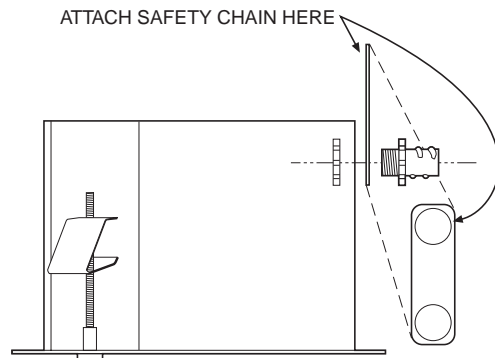

**Figure 5.** Conduit Fitting Installation





**CAUTION:** The ceiling tile must be capable of supporting 16 pounds (7.3 kg) of weight. If the ceiling tile will not support this weight, order the SD5-P metal panel.



**CAUTION:** Be careful not to cut outside of the line. If you do, you may not be able to install the back box. Also, the trim ring may not cover the hole.

## SUSPENDED CEILING

1. Remove the ceiling tile from the ceiling. (The ceiling tile cannot be thinner than 0.50 inch [1.27 cm] nor thicker than 1.75 inches [4.45 cm].)
2. Locate the center point to drill a hole in the tile.
3. Drill a hole in the ceiling tile using a 3/32-inch drill bit.
4. Remove the compass tool from the parts bag that came with the back box (refer to Figure 4). Press the stud of the compass tool into the hole in the ceiling. Insert a pencil in the hole in the other end of the compass and mark a circle on the ceiling.
5. Carefully cut the circle out of the ceiling tile.
6. Remove the conduit fitting, lock nut, and safety chain bracket from the parts bag and attach them to the back box as shown in Figure 5.
7. Refer to Figure 6. Compress the spring clips on the back box with your hands and push the back box through the hole in the ceiling tile. The spring clips will spring out when they clear the ceiling tile.
8. Refer to Figure 7. Tighten the screws until the spring clips hold the back box firmly to the ceiling tile. You will hear a clicking noise when the screws are tight. Do not install the ceiling tile in the ceiling yet.

Proceed to the *Wiring* section.

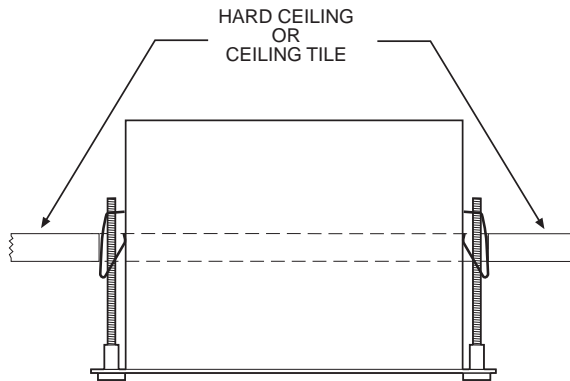

**Figure 6.** Installing Back Box

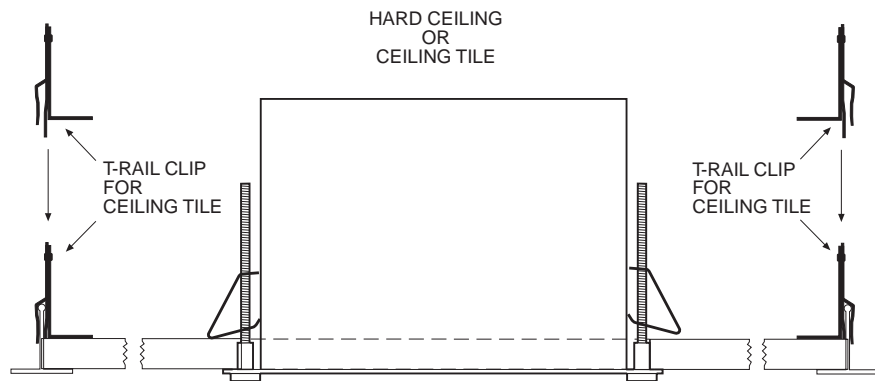

**Figure 7.** Fastening Back Box

## WIRING

Bring wiring to the back box opening in the ceiling. Do not attach the wiring to the back box. You will do that later.

Refer to Figure 8 for the Spectra II™ wiring diagram or Figure 9 for the Spectra Lite™ wiring diagram.

Wiring is required for power, earth ground, and video.

Refer to Table A for the type of video coaxial cable to use.

Input power for the dome is 24 VAC only. Power consumption is 30 vA per dome for indoor models and 75 vA for outdoor models. Refer to Table B to determine the size of wire to use.

Use a 24 VAC transformer with the following minimum vA:

40 vA per dome	For indoor models (without heater)
100 vA per dome	For outdoor models (with heater)

Refer to Figure 11 for wiring multiple domes from the same transformer.

*NOTE: The dome will stop operating if the voltage at the dome drops below 18 VAC. It will turn back on when the voltage exceeds 18 VAC.*

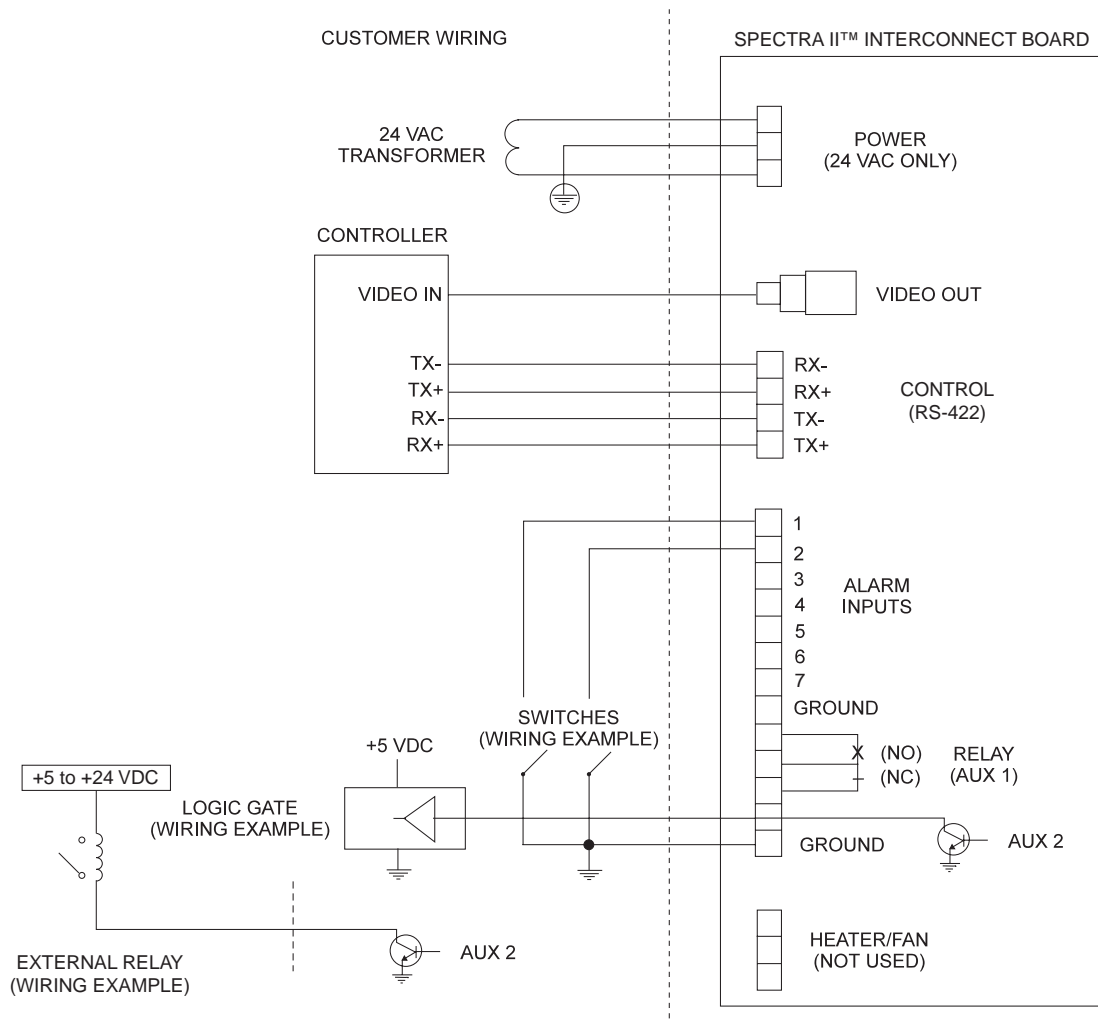

**Figure 8.** Wiring Diagram for Spectra II™

If you are using a Coaxitron® controller, the control signals to operate the dome drive will be transmitted over the video coax. The RS-422 control lines are not used.

If you are not using a Coaxitron® controller, use the RS-422 control lines. Use 22-gauge wire.

Optional wiring for the Spectra II™ dome may be provided for alarm inputs (maximum of seven), relay output (Aux 1), and auxiliary output (Aux 2). For more information about wiring requirements, refer to the *Back Box Connections* section.

Proceed to the *Back Box Installation* section.

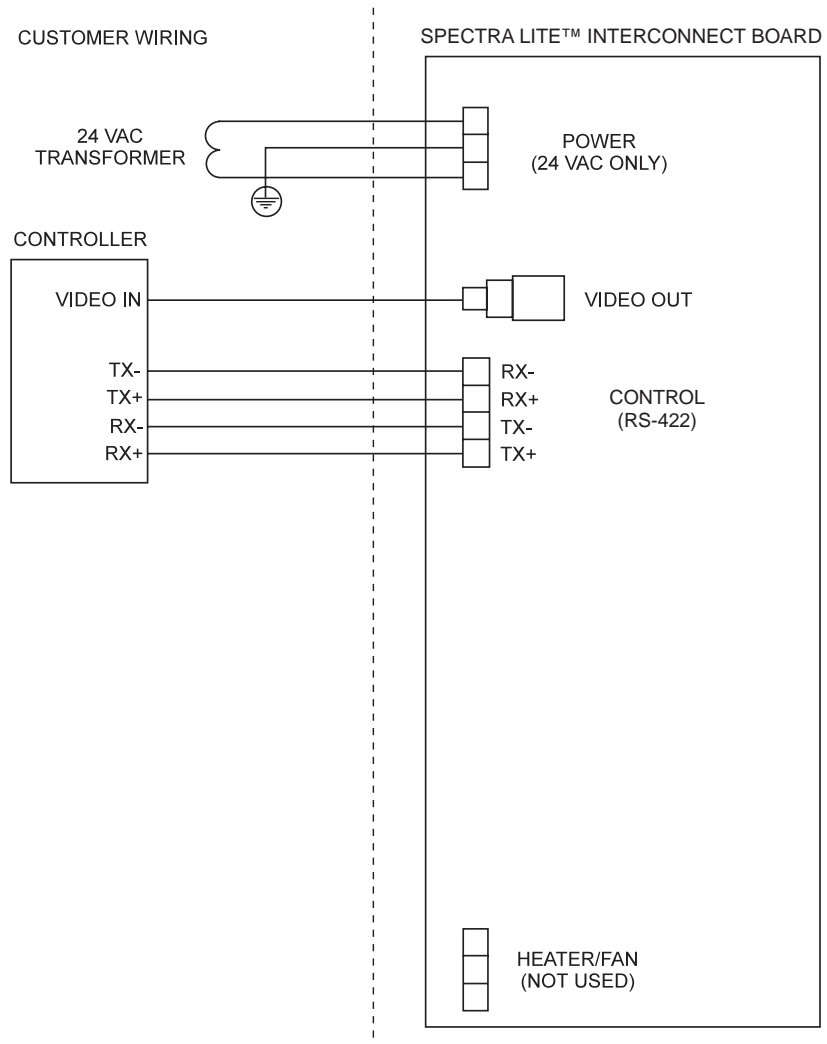

**Figure 9.** Wiring Diagram for Spectra Lite™

**Table A.** Video Coaxial Cable Wiring Distances

Cable Type*	Maximum Distance
RG59/U	750 ft (229 m)
RG6/U	1,000 ft (305 m)
RG11/U	1,500 ft (457 m)

\* Minimum cable requirements:  
75 ohms impedance. All-copper center conductor.  
95% braided copper shield.

**Table B. 24 VAC Wiring Distances**

The following are the recommended maximum distances for 24 VAC with a 10-percent voltage drop. (Ten percent is generally the maximum allowable voltage drop for AC-powered devices.)

	Wire Gauge					
	20	18	16	14	12	10
30 vA	94 ft (28 m)	150 ft (45 m)	238 ft (72 m)	380 ft (115 m)	603 ft (183 m)	960 ft (292 m)
75 vA	37 ft (11 m)	60 ft (18 m)	95 ft (29 m)	152 ft (46 m)	241 ft (73 m)	384 ft (117 m)

## BACK BOX INSTALLATION

**OPTIONAL PROCEDURE:**  
If you prefer, you may make the wiring connections inside the back box before installing the back box in the ceiling.

To do this, loosen the thumbscrew inside the back box and open the hinged door (refer to Figure 10). Bring the wiring into the back box through the conduit fitting. Follow the steps in the Back Box Connections section and then return to this section.



**CAUTION:** The ceiling must be capable of supporting 16 pounds (7.3 kg) of weight. If the ceiling will not support this weight, provide additional reinforcement. Also, a suitable safety chain must be attached to the back box to support up to 16 pounds (7.3 kg) in the event of a ceiling failure.

1. Suspended Ceiling Only (for hard ceiling, go to step 2) – Install the ceiling tile with the back box. Attach a T-rail clip on each side of the ceiling tile as shown in Figure 7.  
  
The clips for the ceiling tile are supplied with the back box. Attach the clip to the T-rail. Fasten the L-bracket to the clip with the supplied screw, lock washer and nut.
2. Install a safety chain or cable (not supplied) that will support up to 16 pounds (7.3 kg). Fasten one end to a support structure in the ceiling. Fasten the other end to the safety chain bracket (refer to Figure 5) to prevent the back box from falling.
3. Refer to Figure 10. Loosen the thumbscrew inside the back box and open the hinged door.
4. Bring the wiring into the back box through the conduit fitting. If the wiring is inside flexible conduit, connect the conduit to the fitting on the back box.
5. Hard Ceiling Only - Refer to Figure 6. Compress the spring clips on the back box with your hands and push the back box through the hole in the ceiling. The spring clips will spring out when they clear the ceiling. Refer to Figure 7. Tighten the screws until the spring clips hold the back box firmly to the ceiling. You will hear a clicking noise when the screws are tight.

Proceed to the *Back Box Connections* section.

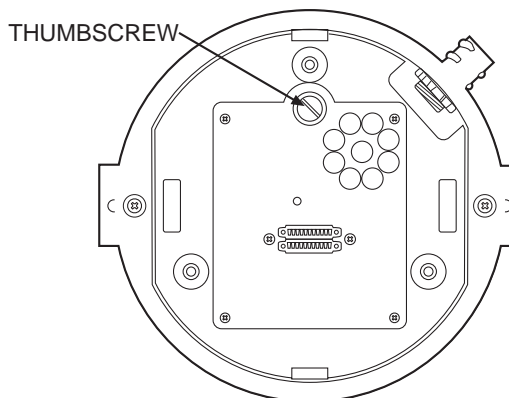

**Figure 10. Interconnect Door**

## BACK BOX CONNECTIONS

**WARNING:** Make sure you wire power to the outer connectors of the terminal block and ground to the middle connector. Otherwise, you could damage the dome.

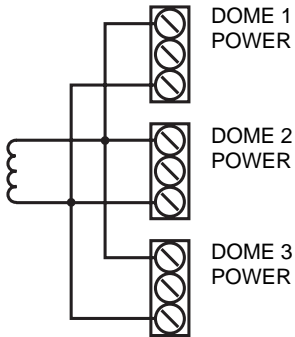

**EXAMPLE:** If each dome requires 30 vA, three domes require a transformer with a minimum output of 120 vA (refer to the Wiring section for transformer requirements).

**Figure 11.** Transformer Wiring

Refer to Figure 12 or 13 to attach the wiring to the interconnect circuit board inside the back box. Also refer to Figure 8 or 9 if necessary.

1. Earth Ground - Connect earth ground to the middle connector on the power connector.
2. Power - Connect 24 VAC from the transformer to the outer terminals on the power connector. It does not matter which lead goes to which terminal.

If you are wiring more than one dome from the same transformer, it is important to wire the power connector in each dome the same way. That is, the wiring from one side of the transformer must be connected to the same connector on each dome. If you reverse the wiring, the cameras will be out of phase with each other and may produce what appears to be vertical roll when switching between cameras. Refer to Figure 11 for a wiring diagram.

3. Video - Connect the coaxial cable to the BNC video connector.
4. Control - If you are using a Coaxitron® controller, control signals will be transmitted over the video coax.

If you are using RS-422 (P or D) control signals, connect the control lines from the controller to the circuit board. Connect the wires as follows:

From controller	To 4-Wire terminal on circuit board
RX-	TX-
RX+	TX+
TX-	RX-
TX+	RX+

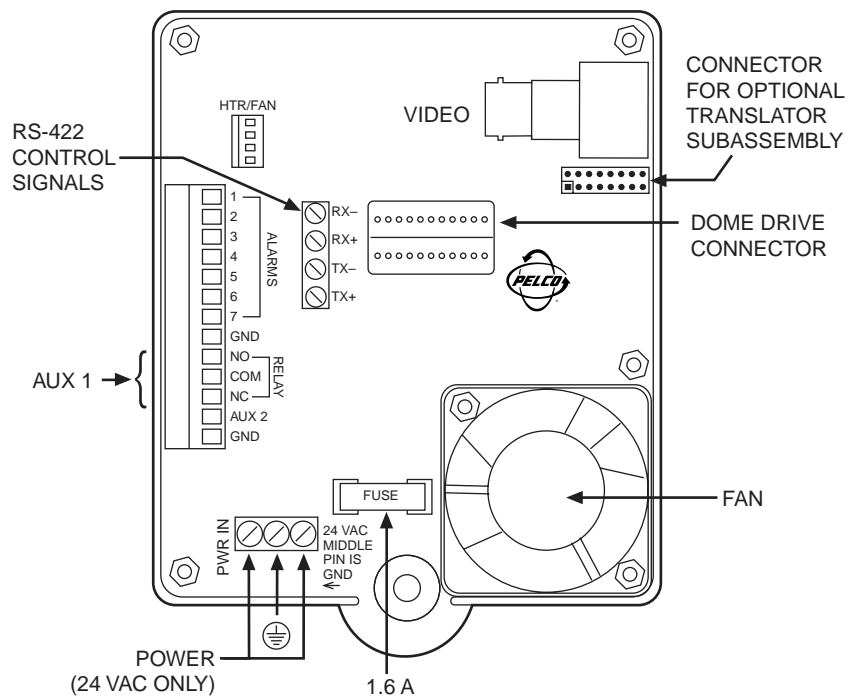

**Figure 12.** Interconnect Circuit Board Electrical Connections for Spectra II™

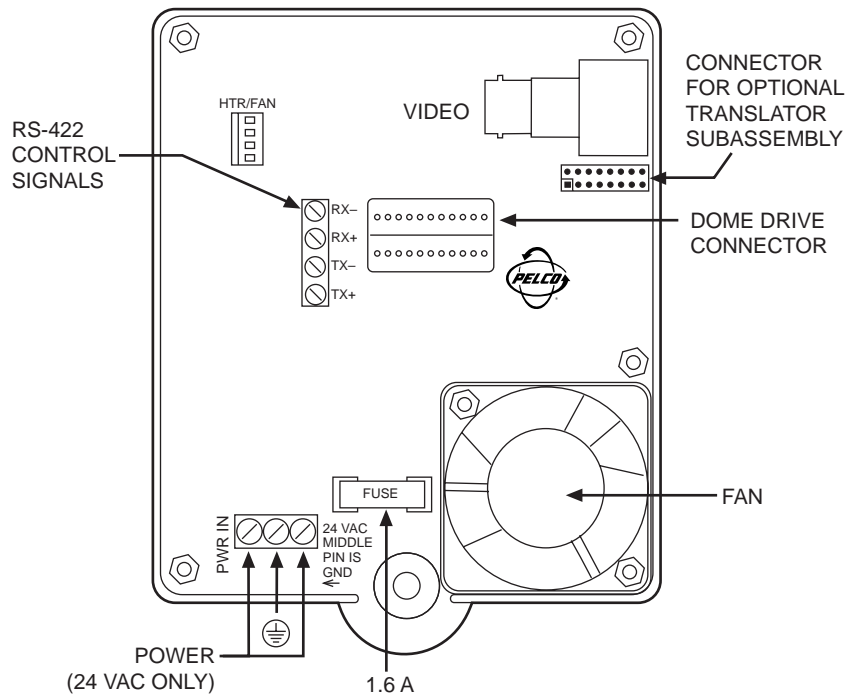

**Figure 13.** Interconnect Circuit Board Electrical Connections for Spectra Lite™

*NOTE: (Spectra II™ Only) Connect only a low voltage device to the relay output. Maximum current rating of the relay contacts is two amperes.*



**CAUTION:** (Spectra II™ Only) The maximum output of AUX 2 is 150 mA. If you connect a device that draws more current, you could destroy the output transistor. The output is intended to drive logic circuits or low-current devices. If higher current is required, connect the output to a relay.



**CAUTION:** Leave adequate slack in the wiring to permit the door to open without pulling on the connectors.

5. Heater/Fan - This is a factory connection for a heater on outdoor pendant models.
6. Alarm Inputs - (Spectra II™ Only) If you need alarm inputs, connect them. The maximum number of alarm inputs is seven. Refer to Figure 8 for a typical wiring example. Alarm inputs require a ground signal through a contact closure, such as a switch.
7. AUX 1 - (Spectra II™ Only) An AUX 1 command from the controller will activate the relay output. If you need the relay, wire it as required. Refer to Figure 8. The relay contacts are shown when AUX 1 is inactive. When an AUX 1 command is issued, the relay contacts will reverse and remain latched until a clear command is issued.
8. AUX 2 - (Spectra II™ Only) An AUX 2 command from the controller will place a ground at the output of AUX 2 to operate the device connected to it. The output will remain latched until a clear command is issued. If you need the AUX 2 output, wire it as required. Refer to Figure 8 for typical wiring examples. The AUX 2 output is an open collector transistor driver that can pass a maximum of 150 mA at 32 VDC. It is capable of driving TTL logic circuits or low-current reed relays. If you use an external relay, make sure that both the supply voltage and the current requirements are well below the maximum of 32 VDC and 150 mA. Exceeding these values will cause permanent damage to the dome. If you are not familiar with open collector drive requirements, contact Pelco technical support for assistance.
9. Close the door and tighten the thumbscrew securely.

Proceed to the *Dome Drive* section.

## DOME DRIVE

*NOTE: For Coaxitron® control, SW2 is not used and all switches must be OFF.*



**CAUTION:** Make sure the dome drive locks into place. Tug downward on the dome drive with moderate pressure to ensure that it stays in place.

1. Turn on power to the back box. The red LED should light to indicate power.  
  
If the LED does not light, correct the trouble before proceeding. Refer to the *Trouble-shooting* section.  
  
If the light is operating, you may either leave the power on and continue with the installation, or you may turn the power off before proceeding further.
2. Set the switches on the bottom of the dome drive. Refer to Figure 14 and Table C for the settings for SW1.  
  
Refer to Figure 14 and Tables D and E for the settings for SW2.
3. Install the dome drive in the back box: Line up the green drive eject tab on the dome drive with the green label on the back box and the red static tab with the red label on the back box. Raise the dome drive into the back box and push on the ends of the tabs until they both click into place on the back box.
4. Turn on power, if it is not on. Listen for the fan operating. If the fan does not work, the dome will overheat and shut down. If the fan does not work, return the back box electronic assembly and dome drive to the factory for repair. Refer to the *Back Box Electronic Assembly Removal* section.

Proceed to the *Lower Dome* section.

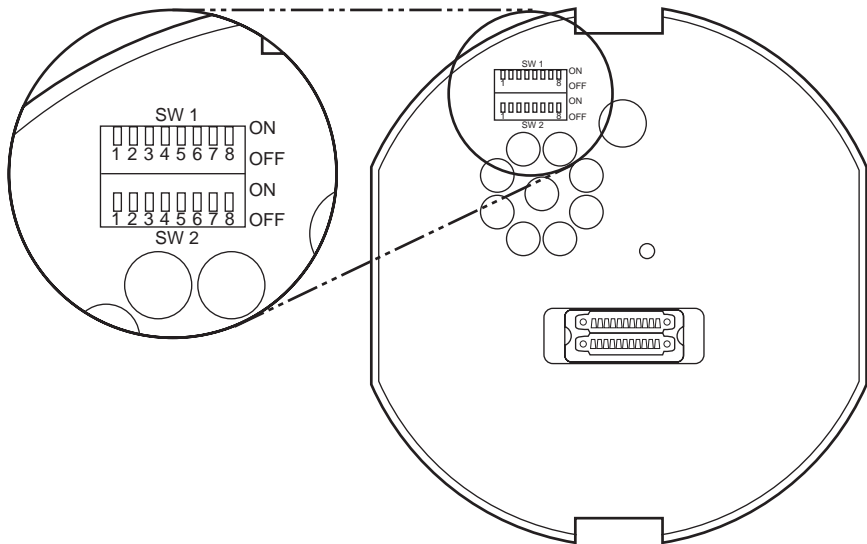

**Figure 14.** Switch Locations

**Table C.** Switch Settings for SW1

Control Type	Switch Setting							
	SW1-1	SW1-2	SW1-3	SW1-4	SW1-5	SW1-6	SW1-7	SW1-8
Coaxitron®	OFF	OFF	OFF	OFF	OFF	OFF	OFF	OFF**
P-Type Control	ON	OFF	OFF	OFF	OFF	OFF	OFF	OFF**
D-Type Control	OFF	ON	OFF	OFF	OFF	OFF	OFF*	OFF**
<p><b>NOTES:</b> Switches SW 1-3 through SW 1-6 <b>MUST</b> be OFF.                      D-type control is RS-422 that is compatible with Pelco's CM6700, MPT9500 and CM8500 controllers or with American Dynamics control systems using the AD2083 Translator.                      P-type control is RS-422 that is compatible with Pelco's CM6700/CM9750/CM9760 control systems.                      * OFF- Use with controllers that have more than 32 presets.                      ON- Use with American Dynamics controllers (32 presets).                      ** OFF - Use with all control systems except CM9502 with <u>variable</u> speed keyboards.                      For CM9502 with <u>fixed</u> speed keyboards, set switch OFF.                      ON - Use with CM9502 with <u>variable</u> speed keyboards for smoother joystick control.</p>								

**Table D. Switch Settings for SW2 – P-Type Control**

*NOTES: For Coaxitron® controls, all switches on SW2 MUST be OFF.  
For D-type control systems, refer to Table E.*

Receiver Address	Switch Setting				
	SW2-1	SW2-2	SW2-3	SW2-4	SW2-5
1	OFF	OFF	OFF	OFF	OFF
2	ON	OFF	OFF	OFF	OFF
3	OFF	ON	OFF	OFF	OFF
4	ON	ON	OFF	OFF	OFF
5	OFF	OFF	ON	OFF	OFF
6	ON	OFF	ON	OFF	OFF
7	OFF	ON	ON	OFF	OFF
8	ON	ON	ON	OFF	OFF
9	OFF	OFF	OFF	ON	OFF
10	ON	OFF	OFF	ON	OFF
11	OFF	ON	OFF	ON	OFF
12	ON	ON	OFF	ON	OFF
13	OFF	OFF	ON	ON	OFF
14	ON	OFF	ON	ON	OFF
15	OFF	ON	ON	ON	OFF
16	ON	ON	ON	ON	OFF
17	OFF	OFF	OFF	OFF	ON
18	ON	OFF	OFF	OFF	ON
19	OFF	ON	OFF	OFF	ON
20	ON	ON	OFF	OFF	ON
21	OFF	OFF	ON	OFF	ON
22	ON	OFF	ON	OFF	ON
23	OFF	ON	ON	OFF	ON
24	ON	ON	ON	OFF	ON
25	OFF	OFF	OFF	ON	ON
26	ON	OFF	OFF	ON	ON
27	OFF	ON	OFF	ON	ON
28	ON	ON	OFF	ON	ON
29	OFF	OFF	ON	ON	ON
30	ON	OFF	ON	ON	ON
31	OFF	ON	ON	ON	ON
32	ON	ON	ON	ON	ON

Baud Rate	Switch Setting		
	SW2-6	SW2-7	SW2-8
2400	OFF	OFF	OFF
4800	ON	OFF	OFF
9600	OFF	ON	OFF



**Table E.** Switch Settings for SW2 – D-Type Control

NOTES: For Coaxitron® controls, all switches on SW2 MUST be OFF.  
For P-type control systems, refer to Table D.

Receiver Address	Switch Setting							
	SW2-1	SW2-2	SW2-3	SW2-4	SW2-5	SW2-6	SW2-7	SW2-8
1	ON	OFF	OFF	OFF	OFF	OFF	OFF	OFF
2	OFF	ON	OFF	OFF	OFF	OFF	OFF	OFF
3	ON	ON	OFF	OFF	OFF	OFF	OFF	OFF
4	OFF	OFF	ON	OFF	OFF	OFF	OFF	OFF
5	ON	OFF	ON	OFF	OFF	OFF	OFF	OFF
6	OFF	ON	ON	OFF	OFF	OFF	OFF	OFF
7	ON	ON	ON	OFF	OFF	OFF	OFF	OFF
8	OFF	OFF	OFF	ON	OFF	OFF	OFF	OFF
9	ON	OFF	OFF	ON	OFF	OFF	OFF	OFF
10	OFF	ON	OFF	ON	OFF	OFF	OFF	OFF
11	ON	ON	OFF	ON	OFF	OFF	OFF	OFF
12	OFF	OFF	ON	ON	OFF	OFF	OFF	OFF
13	ON	OFF	ON	ON	OFF	OFF	OFF	OFF
14	OFF	ON	ON	ON	OFF	OFF	OFF	OFF
15	ON	ON	ON	ON	OFF	OFF	OFF	OFF
16	OFF	OFF	OFF	OFF	ON	OFF	OFF	OFF
17	ON	OFF	OFF	OFF	ON	OFF	OFF	OFF
18	OFF	ON	OFF	OFF	ON	OFF	OFF	OFF
19	ON	ON	OFF	OFF	ON	OFF	OFF	OFF
20	OFF	OFF	ON	OFF	ON	OFF	OFF	OFF
21	ON	OFF	ON	OFF	ON	OFF	OFF	OFF
22	OFF	ON	ON	OFF	ON	OFF	OFF	OFF
23	ON	ON	ON	OFF	ON	OFF	OFF	OFF
24	OFF	OFF	OFF	ON	ON	OFF	OFF	OFF
25	ON	OFF	OFF	ON	ON	OFF	OFF	OFF
26	OFF	ON	OFF	ON	ON	OFF	OFF	OFF
27	ON	ON	OFF	ON	ON	OFF	OFF	OFF
28	OFF	OFF	ON	ON	ON	OFF	OFF	OFF
29	ON	OFF	ON	ON	ON	OFF	OFF	OFF
30	OFF	ON	ON	ON	ON	OFF	OFF	OFF
31	ON	ON	ON	ON	ON	OFF	OFF	OFF
32	OFF	OFF	OFF	OFF	OFF	ON	OFF	OFF
33	ON	OFF	OFF	OFF	OFF	ON	OFF	OFF
34	OFF	ON	OFF	OFF	OFF	ON	OFF	OFF
35	ON	ON	OFF	OFF	OFF	ON	OFF	OFF
36	OFF	OFF	ON	OFF	OFF	ON	OFF	OFF
37	ON	OFF	ON	OFF	OFF	ON	OFF	OFF
38	OFF	ON	ON	OFF	OFF	ON	OFF	OFF
39	ON	ON	ON	OFF	OFF	ON	OFF	OFF
40	OFF	OFF	OFF	ON	OFF	ON	OFF	OFF
41	ON	OFF	OFF	ON	OFF	ON	OFF	OFF
42	OFF	ON	OFF	ON	OFF	ON	OFF	OFF
43	ON	ON	OFF	ON	OFF	ON	OFF	OFF
44	OFF	OFF	ON	ON	OFF	ON	OFF	OFF
45	ON	OFF	ON	ON	OFF	ON	OFF	OFF
46	OFF	ON	ON	ON	OFF	ON	OFF	OFF
47	ON	ON	ON	ON	OFF	ON	OFF	OFF
48	OFF	OFF	OFF	OFF	ON	ON	OFF	OFF
49	ON	OFF	OFF	OFF	ON	ON	OFF	OFF
50	OFF	ON	OFF	OFF	ON	ON	OFF	OFF
51	ON	ON	OFF	OFF	ON	ON	OFF	OFF
52	OFF	OFF	ON	OFF	ON	ON	OFF	OFF
53	ON	OFF	ON	OFF	ON	ON	OFF	OFF
54	OFF	ON	ON	OFF	ON	ON	OFF	OFF
55	ON	ON	ON	OFF	ON	ON	OFF	OFF
56	OFF	OFF	OFF	ON	ON	ON	OFF	OFF

Continued on next page

**Table E.** Switch Settings for SW2 – D-Type Control (continued)

Receiver Address	Switch Setting							
	SW2-1	SW2-2	SW2-3	SW2-4	SW2-5	SW2-6	SW2-7	SW2-8
57	ON	OFF	OFF	ON	ON	ON	OFF	OFF
58	OFF	ON	OFF	ON	ON	ON	OFF	OFF
59	ON	ON	OFF	ON	ON	ON	OFF	OFF
60	OFF	OFF	ON	ON	ON	ON	OFF	OFF
61	ON	OFF	ON	ON	ON	ON	OFF	OFF
62	OFF	ON	ON	ON	ON	ON	OFF	OFF
63	ON	ON	ON	ON	ON	ON	OFF	OFF
64	OFF	OFF	OFF	OFF	OFF	OFF	ON	OFF
65	ON	OFF	OFF	OFF	OFF	OFF	ON	OFF
66	OFF	ON	OFF	OFF	OFF	OFF	ON	OFF
67	ON	ON	OFF	OFF	OFF	OFF	ON	OFF
68	OFF	OFF	ON	OFF	OFF	OFF	ON	OFF
69	ON	OFF	ON	OFF	OFF	OFF	ON	OFF
70	OFF	ON	ON	OFF	OFF	OFF	ON	OFF
71	ON	ON	ON	OFF	OFF	OFF	ON	OFF
72	OFF	OFF	OFF	ON	OFF	OFF	ON	OFF
73	ON	OFF	OFF	ON	OFF	OFF	ON	OFF
74	OFF	ON	OFF	ON	OFF	OFF	ON	OFF
75	ON	ON	OFF	ON	OFF	OFF	ON	OFF
76	OFF	OFF	ON	ON	OFF	OFF	ON	OFF
77	ON	OFF	ON	ON	OFF	OFF	ON	OFF
78	OFF	ON	ON	ON	OFF	OFF	ON	OFF
79	ON	ON	ON	ON	OFF	OFF	ON	OFF
80	OFF	OFF	OFF	OFF	ON	OFF	ON	OFF
81	ON	OFF	OFF	OFF	ON	OFF	ON	OFF
82	OFF	ON	OFF	OFF	ON	OFF	ON	OFF
83	ON	ON	OFF	OFF	ON	OFF	ON	OFF
84	OFF	OFF	ON	OFF	ON	OFF	ON	OFF
85	ON	OFF	ON	OFF	ON	OFF	ON	OFF
86	OFF	ON	ON	OFF	ON	OFF	ON	OFF
87	ON	ON	ON	OFF	ON	OFF	ON	OFF
88	OFF	OFF	OFF	ON	ON	OFF	ON	OFF
89	ON	OFF	OFF	ON	ON	OFF	ON	OFF
90	OFF	ON	OFF	ON	ON	OFF	ON	OFF
91	ON	ON	OFF	ON	ON	OFF	ON	OFF
92	OFF	OFF	ON	ON	ON	OFF	ON	OFF
93	ON	OFF	ON	ON	ON	OFF	ON	OFF
94	OFF	ON	ON	ON	ON	OFF	ON	OFF
95	ON	ON	ON	ON	ON	OFF	ON	OFF
96	OFF	OFF	OFF	OFF	OFF	ON	ON	OFF
97	ON	OFF	OFF	OFF	OFF	ON	ON	OFF
98	OFF	ON	OFF	OFF	OFF	ON	ON	OFF
99	ON	ON	OFF	OFF	OFF	ON	ON	OFF
100	OFF	OFF	ON	OFF	OFF	ON	ON	OFF
101	ON	OFF	ON	OFF	OFF	ON	ON	OFF
102	OFF	ON	ON	OFF	OFF	ON	ON	OFF
103	ON	ON	ON	OFF	OFF	ON	ON	OFF
104	OFF	OFF	OFF	ON	OFF	ON	ON	OFF
105	ON	OFF	OFF	ON	OFF	ON	ON	OFF
106	OFF	ON	OFF	ON	OFF	ON	ON	OFF
107	ON	ON	OFF	ON	OFF	ON	ON	OFF
108	OFF	OFF	ON	ON	OFF	ON	ON	OFF
109	ON	OFF	ON	ON	OFF	ON	ON	OFF
110	OFF	ON	ON	ON	OFF	ON	ON	OFF
111	ON	ON	ON	ON	OFF	ON	ON	OFF
112	OFF	OFF	OFF	OFF	ON	ON	ON	OFF
113	ON	OFF	OFF	OFF	ON	ON	ON	OFF
114	OFF	ON	OFF	OFF	ON	ON	ON	OFF
115	ON	ON	OFF	OFF	ON	ON	ON	OFF
116	OFF	OFF	ON	OFF	ON	ON	ON	OFF

Continued on next page

**Table E.** Switch Settings for SW2 – D-Type Control (continued)

Receiver Address	Switch Setting							
	SW2-1	SW2-2	SW2-3	SW2-4	SW2-5	SW2-6	SW2-7	SW2-8
117	ON	OFF	ON	OFF	ON	ON	ON	OFF
118	OFF	ON	ON	OFF	ON	ON	ON	OFF
119	ON	ON	ON	OFF	ON	ON	ON	OFF
120	OFF	OFF	OFF	ON	ON	ON	ON	OFF
121	ON	OFF	OFF	ON	ON	ON	ON	OFF
122	OFF	ON	OFF	ON	ON	ON	ON	OFF
123	ON	ON	OFF	ON	ON	ON	ON	OFF
124	OFF	OFF	ON	ON	ON	ON	ON	OFF
125	ON	OFF	ON	ON	ON	ON	ON	OFF
126	OFF	ON	ON	ON	ON	ON	ON	OFF
127	ON	ON	ON	ON	ON	ON	ON	OFF
128	OFF	OFF	OFF	OFF	OFF	OFF	OFF	ON
129	ON	OFF	OFF	OFF	OFF	OFF	OFF	ON
130	OFF	ON	OFF	OFF	OFF	OFF	OFF	ON
131	ON	ON	OFF	OFF	OFF	OFF	OFF	ON
132	OFF	OFF	ON	OFF	OFF	OFF	OFF	ON
133	ON	OFF	ON	OFF	OFF	OFF	OFF	ON
134	OFF	ON	ON	OFF	OFF	OFF	OFF	ON
135	ON	ON	ON	OFF	OFF	OFF	OFF	ON
136	OFF	OFF	OFF	ON	OFF	OFF	OFF	ON
137	ON	OFF	OFF	ON	OFF	OFF	OFF	ON
138	OFF	ON	OFF	ON	OFF	OFF	OFF	ON
139	ON	ON	OFF	ON	OFF	OFF	OFF	ON
140	OFF	OFF	ON	ON	OFF	OFF	OFF	ON
141	ON	OFF	ON	ON	OFF	OFF	OFF	ON
142	OFF	ON	ON	ON	OFF	OFF	OFF	ON
143	ON	ON	ON	ON	OFF	OFF	OFF	ON
144	OFF	OFF	OFF	OFF	ON	OFF	OFF	ON
145	ON	OFF	OFF	OFF	ON	OFF	OFF	ON
146	OFF	ON	OFF	OFF	ON	OFF	OFF	ON
147	ON	ON	OFF	OFF	ON	OFF	OFF	ON
148	OFF	OFF	ON	OFF	ON	OFF	OFF	ON
149	ON	OFF	ON	OFF	ON	OFF	OFF	ON
150	OFF	ON	ON	OFF	ON	OFF	OFF	ON
151	ON	ON	ON	OFF	ON	OFF	OFF	ON
152	OFF	OFF	OFF	ON	ON	OFF	OFF	ON
153	ON	OFF	OFF	ON	ON	OFF	OFF	ON
154	OFF	ON	OFF	ON	ON	OFF	OFF	ON
155	ON	ON	OFF	ON	ON	OFF	OFF	ON
156	OFF	OFF	ON	ON	ON	OFF	OFF	ON
157	ON	OFF	ON	ON	ON	OFF	OFF	ON
158	OFF	ON	ON	ON	ON	OFF	OFF	ON
159	ON	ON	ON	ON	ON	OFF	OFF	ON
160	OFF	OFF	OFF	OFF	OFF	ON	OFF	ON
161	ON	OFF	OFF	OFF	OFF	ON	OFF	ON
162	OFF	ON	OFF	OFF	OFF	ON	OFF	ON
163	ON	ON	OFF	OFF	OFF	ON	OFF	ON
164	OFF	OFF	ON	OFF	OFF	ON	OFF	ON
165	ON	OFF	ON	OFF	OFF	ON	OFF	ON
166	OFF	ON	ON	OFF	OFF	ON	OFF	ON
167	ON	ON	ON	OFF	OFF	ON	OFF	ON
168	OFF	OFF	OFF	ON	OFF	ON	OFF	ON
169	ON	OFF	OFF	ON	OFF	ON	OFF	ON
170	OFF	ON	OFF	ON	OFF	ON	OFF	ON
171	ON	ON	OFF	ON	OFF	ON	OFF	ON
172	OFF	OFF	ON	ON	OFF	ON	OFF	ON
173	ON	OFF	ON	ON	OFF	ON	OFF	ON
174	OFF	ON	ON	ON	OFF	ON	OFF	ON
175	ON	ON	ON	ON	OFF	ON	OFF	ON
176	OFF	OFF	OFF	OFF	ON	ON	OFF	ON

Continued on next page

**Table E.** Switch Settings for SW2 - D-Type Control (continued)

Receiver Address	Switch Setting							
	SW2-1	SW2-2	SW2-3	SW2-4	SW2-5	SW2-6	SW2-7	SW2-8
177	ON	OFF	OFF	OFF	ON	ON	OFF	ON
178	OFF	ON	OFF	OFF	ON	ON	OFF	ON
179	ON	ON	OFF	OFF	ON	ON	OFF	ON
180	OFF	OFF	ON	OFF	ON	ON	OFF	ON
181	ON	OFF	ON	OFF	ON	ON	OFF	ON
182	OFF	ON	ON	OFF	ON	ON	OFF	ON
183	ON	ON	ON	OFF	ON	ON	OFF	ON
184	OFF	OFF	OFF	ON	ON	ON	OFF	ON
185	ON	OFF	OFF	ON	ON	ON	OFF	ON
186	OFF	ON	OFF	ON	ON	ON	OFF	ON
187	ON	ON	OFF	ON	ON	ON	OFF	ON
188	OFF	OFF	ON	ON	ON	ON	OFF	ON
189	ON	OFF	ON	ON	ON	ON	OFF	ON
190	OFF	ON	ON	ON	ON	ON	OFF	ON
191	ON	ON	ON	ON	ON	ON	OFF	ON
192	OFF	OFF	OFF	OFF	OFF	OFF	ON	ON
193	ON	OFF	OFF	OFF	OFF	OFF	ON	ON
194	OFF	ON	OFF	OFF	OFF	OFF	ON	ON
195	ON	ON	OFF	OFF	OFF	OFF	ON	ON
196	OFF	OFF	ON	OFF	OFF	OFF	ON	ON
197	ON	OFF	ON	OFF	OFF	OFF	ON	ON
198	OFF	ON	ON	OFF	OFF	OFF	ON	ON
199	ON	ON	ON	OFF	OFF	OFF	ON	ON
200	OFF	OFF	OFF	ON	OFF	OFF	ON	ON
201	ON	OFF	OFF	ON	OFF	OFF	ON	ON
202	OFF	ON	OFF	ON	OFF	OFF	ON	ON
203	ON	ON	OFF	ON	OFF	OFF	ON	ON
204	OFF	OFF	ON	ON	OFF	OFF	ON	ON
205	ON	OFF	ON	ON	OFF	OFF	ON	ON
206	OFF	ON	ON	ON	OFF	OFF	ON	ON
207	ON	ON	ON	ON	OFF	OFF	ON	ON
208	OFF	OFF	OFF	OFF	ON	OFF	ON	ON
209	ON	OFF	OFF	OFF	ON	OFF	ON	ON
210	OFF	ON	OFF	OFF	ON	OFF	ON	ON
211	ON	ON	OFF	OFF	ON	OFF	ON	ON
212	OFF	OFF	ON	OFF	ON	OFF	ON	ON
213	ON	OFF	ON	OFF	ON	OFF	ON	ON
214	OFF	ON	ON	OFF	ON	OFF	ON	ON
215	ON	ON	ON	OFF	ON	OFF	ON	ON
216	OFF	OFF	OFF	ON	ON	OFF	ON	ON
217	ON	OFF	OFF	ON	ON	OFF	ON	ON
218	OFF	ON	OFF	ON	ON	OFF	ON	ON
219	ON	ON	OFF	ON	ON	OFF	ON	ON
220	OFF	OFF	ON	ON	ON	OFF	ON	ON
221	ON	OFF	ON	ON	ON	OFF	ON	ON
222	OFF	ON	ON	ON	ON	OFF	ON	ON
223	ON	ON	ON	ON	ON	OFF	ON	ON
224	OFF	OFF	OFF	OFF	OFF	ON	ON	ON
225	ON	OFF	OFF	OFF	OFF	ON	ON	ON
226	OFF	ON	OFF	OFF	OFF	ON	ON	ON
227	ON	ON	OFF	OFF	OFF	ON	ON	ON
228	OFF	OFF	ON	OFF	OFF	ON	ON	ON
229	ON	OFF	ON	OFF	OFF	ON	ON	ON
230	OFF	ON	ON	OFF	OFF	ON	ON	ON
231	ON	ON	ON	OFF	OFF	ON	ON	ON
232	OFF	OFF	OFF	ON	OFF	ON	ON	ON
233	ON	OFF	OFF	ON	OFF	ON	ON	ON
234	OFF	ON	OFF	ON	OFF	ON	ON	ON
235	ON	ON	OFF	ON	OFF	ON	ON	ON
236	OFF	OFF	ON	ON	OFF	ON	ON	ON

Continued on next page

**Table E.** Switch Settings for SW2 - D-Type Control (continued)

Receiver Address	Switch Setting							
	SW2-1	SW2-2	SW2-3	SW2-4	SW2-5	SW2-6	SW2-7	SW2-8
237	ON	OFF	ON	ON	OFF	ON	ON	ON
238	OFF	ON	ON	ON	OFF	ON	ON	ON
239	ON	ON	ON	ON	OFF	ON	ON	ON
240	OFF	OFF	OFF	OFF	ON	ON	ON	ON
241	ON	OFF	OFF	OFF	ON	ON	ON	ON
242	OFF	ON	OFF	OFF	ON	ON	ON	ON
243	ON	ON	OFF	OFF	ON	ON	ON	ON
244	OFF	OFF	ON	OFF	ON	ON	ON	ON
245	ON	OFF	ON	OFF	ON	ON	ON	ON
246	OFF	ON	ON	OFF	ON	ON	ON	ON
247	ON	ON	ON	OFF	ON	ON	ON	ON
248	OFF	OFF	OFF	ON	ON	ON	ON	ON
249	ON	OFF	OFF	ON	ON	ON	ON	ON
250	OFF	ON	OFF	ON	ON	ON	ON	ON
251	ON	ON	OFF	ON	ON	ON	ON	ON
252	OFF	OFF	ON	ON	ON	ON	ON	ON
253	ON	OFF	ON	ON	ON	ON	ON	ON
254	OFF	ON	ON	ON	ON	ON	ON	ON

## LOWER DOME

1. Snap the clip on the end of the trim ring leash into the hole on the lip of the back box next to one of the mounting screws.
2. Line up the snaps on the trim ring with the mounting screws on the back box. Snap the trim ring into place on the plastic snap washers on the mounting screws.

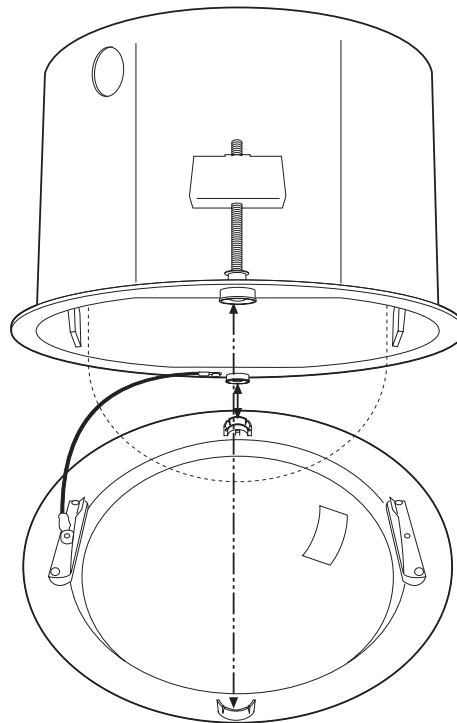

**Figure 15.** Lower Dome Installation, In-Ceiling Models

# INSTALLATION FOR PENDANT MODELS

## PENDANT-MOUNT INSTALLATION

*NOTE: If outdoors, apply Duct Seal inside the pipe portion of the back box to prevent moisture or cold air inside the mount from entering the unit and causing condensation on the dome. Make sure no moisture has condensed inside the unit before installing the lower dome. Duct Seal can be purchased through local electrical supply houses.*

1. Install the pendant dome mount. Refer to the instructions supplied with the mount. If the mount is outdoors, make sure it is properly sealed to keep moisture out.
2. Bring the wiring for the dome through the mount. Refer to the *Wiring* section.
3. Refer to Figure 10. Loosen the thumbscrew inside the back box and open the hinged door.
4. Screw the back box into the mount and bring the wiring into the back box. If outdoors, apply the provided pipe sealant to the threads on the back box.
5. Attach the wiring to the back box. Refer to the *Back Box Connections* section.
6. Install the dome drive. Refer to the *Dome Drive* section.
7. Remove the O-ring and O-ring lubricant from the parts bag. Lightly apply lubricant to the O-ring so that it is just moistened; do not use excess lubricant. Install the O-ring in the groove on the trim ring of the lower dome.
8. Refer to Figure 16. Hanging down from the back box is a short cable (the trim ring leash). Hold up the lower dome near the back box so that the trim ring leash touches the lower dome. Line up the two screw holes in the trim ring of the lower dome with the two screw holes in the back box. Place a finger on the edge of the trim ring where the leash touches the lower dome.
9. Look inside the lower dome and note which of the six retainer screws is closest to your finger. Remove this screw and attach the trim ring leash to the screw. Reinstall the screw securely and make sure the leash will hold the lower dome.

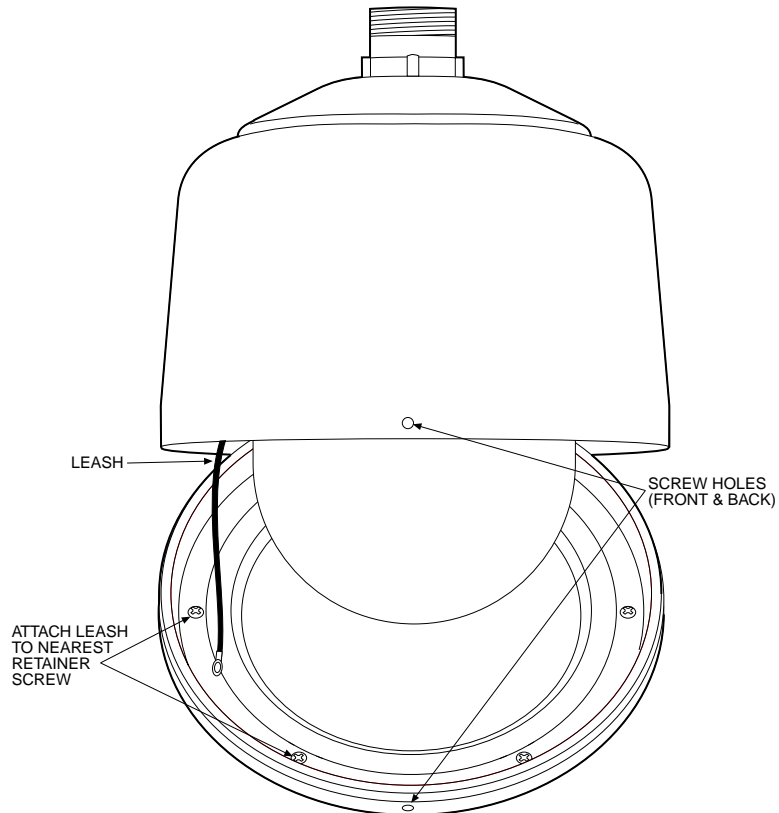

**Figure 16.** Lower Dome Installation, Pendant Models

10. If you are installing an outdoor model, plug the two-pin heater connection in the lower dome into the mating connector in the back box.
11. Remove the two screws and the tube of Loctite® from the parts bag. Apply a drop of Loctite® to each screw.
12. Push the lower dome inside the back box, line up the screw holes, and install the two screws.

## SURFACE-MOUNT INSTALLATION

*NOTE: For hard ceilings, such as concrete, where the wiring must be installed in surface-mounted conduit, use the optional BB5-PCA-BK (black) or BB5-PCA-GY (gray) Pendant Conduit Adapter.*

1. Use a hole saw to drill a hole in the ceiling where you want to hang the pendant dome.
2. Bring the wiring for the dome to the opening. Refer to the *Wiring* section.
3. Refer to Figure 10. Loosen the thumbscrew inside the back box and open the hinged door.
4. Remove the gasket and the top mount from the back box by taking out the three screws and lock washers.
5. Attach the back box to the ceiling using #8 hardware (not supplied).
6. Attach the wiring to the back box. Refer to the *Back Box Connections* section.
7. Install the dome drive. Refer to the *Dome Drive* section.
8. Remove the O-ring and O-ring lubricant from the parts bag. Apply lubricant to the O-ring. Install the O-ring in the groove on the trim ring of the lower dome.
9. Refer to Figure 16. Hanging down from the back box is a short cable (the trim ring leash). Hold up the lower dome near the back box so that the trim ring leash touches the lower dome. Line up the two screw holes in the trim ring of the lower dome with the two screw holes in the back box. Place a finger on the edge of the trim ring where the leash touches the lower dome.
10. Look inside the lower dome and note which of the six retainer screws is closest to your finger. Remove this screw and attach the trim ring leash to the screw. Reinstall the screw securely and make sure the leash will hold the lower dome.
11. If you are installing an outdoor model, plug the two-pin heater connection in the lower dome into the mating connector in the back box.
12. Remove the two screws and the tube of Loctite® from the parts bag. Apply a drop of Loctite® to each screw.
13. Push the lower dome inside the back box, line up the screw holes, and install the two screws.

## OPERATION

The red LED in the interconnect door in the back box lights when power is turned on and the fan operates to exhaust heat from inside the back box.

If you have an outdoor pendant model with a heater, the heater elements in the back box turn on at 70°F (21°C) and turn off at 85°F (29°C). The heater element in the lower dome turns on at 40°F (4°C) and turns off at 60°F (16°C). The fans in the back box operate continuously.

## POWER-UP DISPLAY

When the Spectra II™ dome or Spectra Lite™ dome is powered up or reset, the selected protocol, revision number, and other information is displayed on the monitor. For example, the screen might show the following information:

```
PELCO SPECT II 4.0
CONFIGURE DONE
```

```
Protocol C
```

*NOTE: The dome will stop operating if the voltage at the dome drops below 18 VAC. It will turn back on and go through its start-up routine when the voltage exceeds 18 VAC.*

The information remains on the monitor until the dome is moved. The information displayed depends on the selected protocol and the choice made on the menu for selectable power-up mode, a feature that lets the dome resume a desired condition upon power-up. As a default, the dome goes to a random position. (Refer to the *Power-Up Mode* section).

The control system protocol (C, D, or P) appears. C is for Pelco's Coaxitron® control systems. D-type control is RS-422 that is compatible with Pelco's CM6700, MPT9500 and CM8500 controllers or with American Dynamics control systems using the AD2083 Translator. P-type control is RS-422 that is compatible with Pelco's CM6700 and CM9750/CM9760 control systems.

For the D and P protocols, the device address, baud rate, parity (N), number of data bits (8), and number of stop bits (1) appears. For the D protocol, if the mode for 32 presets is selected (SW1-7 is ON), "32 presets" appears.

If the CM9500 mode is selected (SW1-8 is ON), "CM9500 mode" appears.

## PAN AND TILT FUNCTIONS

Use the joystick on your controller to control pan and tilt functions.

Pan and tilt operation is at a fixed speed with fixed-speed controllers. The speed is determined by the controller.

Standard pan operation with variable-speed controllers will range from 0.5 to 80 degrees per second, depending on the position of the joystick. In the turbo mode, pan speed will be 150 degrees per second. When performing preset operations, pan speed will be 250 degrees per second.

Standard tilt operation with variable-speed controllers will range from 0.5 to 40 degrees per second, depending on the position of the joystick. When performing preset operations, tilt speed will be 200 degrees per second. Turbo mode does not affect the tilt speed.

(Spectra II™ Only) If the proportional pan mode is enabled (refer to the *Proportional Pan* section), the pan (and tilt) speed will depend on the amount of zoom. At telephoto zoom settings, the pan (and tilt) speeds will be slower for a given amount of joystick deflection than at wide zoom settings. This keeps the image from moving too fast on the monitor when there is a large amount of zoom. This slowing does not happen when going to a preset, but does occur in turbo mode when high zoom is selected.

### AUTO FLIP

When the camera tilts downward and goes just beyond the vertical position, the dome rotates 180 degrees. When the dome rotates (flips), the camera starts moving upward as long as you continue to hold the joystick in the down position. Once you let go of the joystick after the dome rotates, joystick control returns to normal operation. The auto-flip feature is useful for following a person who passes directly beneath the camera.

You can disable this feature in the auto flip programming menu. Refer to *Auto Flip* in the *Programming the Spectra II™ and Spectra Lite™* section.

### SCAN SPEED

Scan speed is adjustable from 1 to 40 degrees per second through the programming menu.



## ZOOM

*NOTE: (Spectra II™ Only) On some controllers the zoom speed can be changed. Refer to the documentation for your controller.*

### SPECTRA II™ ZOOM

The Spectra II™ dome can magnify an object up to 128 times. The dome has 16X of optical zoom and 8X of electronic (digital) zoom for 128X total zoom. The amount of zoom can be set for 16X, 32X, 64X, or 128X. Software controls the amount of zoom. Refer to the *Zoom Limit* section to program the zoom limits.

#### 16X or 32X Zoom

Press the Zoom Tele button to magnify an object up to 16 or 32 times. Hold down the button until you have the picture you want.

#### 64X or 128X Zoom

1. Press the Zoom Tele button until the picture reaches 32X zoom.
2. Release the button.
3. Within one second, press the button again until you have the picture you want.

#### Zoom Wide

Press the Zoom Wide button to increase the field of view.

### SPECTRA LITE™ ZOOM

The Spectra Lite™ dome can magnify an object up to 12 times (the dome has 12X of optical zoom).

**Zoom Telephoto** - Press and hold down the Zoom Tele button until you have the picture you want.

**Zoom Wide** - Press the Zoom Wide button to increase the field of view.

## PRESET FUNCTIONS

*NOTE: For American Dynamics controllers with only 32 presets, set switch SW1-7 on the dome drive in the ON position. When SW1-7 is ON, preset*

*99 becomes 32  
98 becomes 31  
97 becomes 30  
96 becomes 29  
95 becomes 28  
93 becomes 26  
92 becomes 25  
91 becomes 24  
90 becomes 23*

*If the limit stops are turned off (refer to the Limit Stops section), presets 23-26 can be used as regular presets.*

The Spectra II™ dome is capable of going to 64 preset locations, each with a 20-character label. The presets are numbered 1-32 and 35-66. The Spectra Lite™ dome can go to 32 presets. The presets are numbered 1-32.

Refer to the documentation for your control system for programming presets.

When a preset operation is performed, the amount of error in moving to the pan and tilt position is 1/2 degree. If you command the dome to go to an undefined preset, erratic operation may result.

Presets 33 and 34 are fixed commands, meaning that you cannot program them. Preset 33 is the "flip" command, which will pan the dome drive 180 degrees from the position it is at. Preset 34 is the "pan zero" command, which will direct the dome drive to the factory-determined zero reference point.

The following presets are reserved for special functions. (An asterisk denotes presets that apply to Spectra II only.)

<u>Preset</u>	<u>Function</u>
1	Park
1-7*	Alarms, if used
33	Flip command
34	Pan zero command
90-93	Limit stops
95	Select camera programming menu
96	Stop a scan
97-99	Activate scanning

In the following sections, sometimes a number in parentheses follows a preset. This second number is for 32-preset mode (conversion that lets Pelco's presets work with American Dynamics controllers). If you are using an American Dynamics controller, use the number in parentheses.

## RANDOM, FRAME, AND AUTO SCANNING

Program preset 97 (30) to start random scanning. Program preset 98 (31) to activate frame scanning (three seconds of scanning followed by a three-second pause). Program preset 99 (32) to start auto (continuous) scanning.

Scan limit stops are controlled by software. Refer to the *Limit Stops* section to program the scan limit stops.

When the dome reaches a scan limit stop, it will immediately reverse direction.

Program preset 96 (29) to stop a scan. Any pan/tilt or lens command also will stop a scan.

## ZONES

(This section applies to Spectra II™ only.)

The Spectra II™ dome is capable of eight zones, each with a 20-character label. Depending on the controller, you can define the zone size and define any zone as “blanked” for video when the camera pans into the zone area. If zone labels are turned off, the system displays the message VIDEO BLANK to indicate the video is being blanked and is not failing. (Refer to the *Zone Blank* section for instructions.) For other information on programming zones, refer to the documentation for your control system.

## PATTERNS

*NOTE: Changing the length erases all stored patterns.*

(This section applies to Spectra II™ only.)

The Spectra II™ dome can do either one full pattern (1.5, 3, or 6 minutes long) or two half patterns (.75, 1.5, or 3 minutes long). This pattern can consist of any standard pan and tilt or lens command. Presets, flip, and turbo are not allowed in a pattern. Zone scan can be enabled while running a pattern.

Refer to the documentation for your control system to program and run patterns.

## ALARMS

(This section applies to Spectra II™ only.)

The Spectra II™ dome has seven alarm inputs, which can be designated as either high or low priority through its programming menu. When an alarm is received, the dome does one of the following:

- Moves to the preset position that corresponds to the alarm number. For example, if alarm 3 is activated, the dome moves to preset 3.
- Runs a half pattern or full pattern as programmed in the Alarm Pattern submenu.

If any of presets 1-7 are not used for alarms, they can be used as regular presets. However, if they are being used for alarms, they should not be used for anything else.

If an alarm input is programmed to run a pattern, the corresponding preset can be used as a regular preset. For example, if alarm 3 is programmed to run a pattern, preset 3 can be used as a regular preset.

There is no indication at the controller that an alarm has been received, other than the view displayed on the monitor.

The high priority setting (if set on the programming menu) is significant when more than one alarm is activated. If priority in alarms is not required, leave all alarms in the low setting.

- If the activated alarm inputs have the same priority—all low or all high—then the dome will sequence between the presets that correspond to the alarm numbers.
- If the activated alarm inputs have different priorities—for example, one is high and four are low—the dome goes only to the high. It remains fixed on the high and only goes to the low after the high has been cleared.

In certain situations, the dome will respond as follows:

- If a preset has not been set, but an alarm is connected: the dome will go to a factory preset that will not be the desired position.
- If one alarm is a preset and another is a pattern and both are received: the dome will alternate between them.

An alarm clears by returning to its former (off) state.

Depending on choices made on the programming menu, the dome can respond to an alarm by running one of the patterns below. (Refer to the *Patterns* section for more information.)

- Run full pattern
- Run half pattern 1
- Run half pattern 2

When sequencing between presets, the dwell time depends on the time set on the Alarm Dwell submenu for that preset. After the dwell time expires, the dome immediately does one of the following:

- If the resume feature was selected on the programming menu and there are no other alarms activated, the dome resumes its prior activity. So, it might return to its previous position or resume a scan or pattern.
- If there are other alarms activated, the dome goes to them.

If you move the joystick to pan or tilt the dome, or if you issue a lens command while there is an alarm, the pan and tilt or lens command overrides the alarm. Sixty seconds after the last pan and tilt or lens command, the dome will return to the alarm preset if the alarm is still active.

## AUXILIARY OUTPUTS

(This section applies to Spectra II™ only.)

An AUX 1 command from the controller will activate the relay in the dome and operate the device that is connected to the relay. The relay will remain latched until a clear command is issued.

An AUX 2 command from the controller will place a ground at the output of AUX 2 to operate the device that is connected to it. The output will remain latched until a clear command is issued. Refer to the *Back Box Connections* section for precautions regarding the use of the AUX 2 output.

The output relay can also be programmed so that it is activated when any alarm input is activated. When latching (toggling) is selected on the programming menu, giving the AUX 1 command from the controller changes the state of the AUX (for example, if it was on, this turns it off.) The clear command from the controller will turn the AUX off in the latching or toggle mode.

## PARK

If the Spectra II™ dome does not receive any commands for a specified period of time (refer to the *Park Time Minutes* section), the dome will go to preset 1 and park. If the time specified is zero, or if preset 1 has not been programmed, the dome will not park. The default is zero minutes.

## PROGRAMMING THE SPECTRA II™ AND SPECTRA LITE™

The Spectra II™ and Spectra Lite™ domes can be programmed for the following functions. (In this section, an asterisk denotes items that apply to Spectra II only.)

AGC (automatic gain control)	Auto park time	Power-up mode
Alarm dwell*	Auxiliary relays*	Proportional panning*
Alarm pattern*	Backlight compensation	Scan speed
Alarm priority*	Camera reset	Sharpness
Alarm resume*	Gain	Shutter speed
Auto flip disable	Limit stops	Video zone blanking*
Auto focus*	Pattern length*	White balance
Auto iris	Power line synchronization*	Zoom limit*

The main menu contains six secondary menus for Spectra II™ and three for Spectra Lite™.

- Camera
- Line Sync\*
- Power Up Mode
- Aux\*
- Alarms, Zone Blank\*
- Other

Each secondary menu has submenus, which are structured as shown below.

1. Camera
 

<u>First Camera Submenu</u> Backlight comp Zoom limit* Reset camera Gain/AGC AGC mode Gain Auto-iris Auto-iris mode Auto-iris level Auto-iris peak Next (to second camera submenu)	<u>Second Camera Submenu</u> Shutter speed Auto focus mode* Sharpness Auto sharpness Sharpness White balance Auto white bal R-B white bal M-G white bal Prev (to first camera submenu)
---------------------------------------------------------------------------------------------------------------------------------------------------------------------------------------------------------------------	----------------------------------------------------------------------------------------------------------------------------------------------------------------------------------------------------------------------
2. Line Sync\*
  - Line sync\*
  - Line sync phase\*
3. Power Up
  - Power Up
4. Aux\*
  - Aux 1 mode\*
  - Aux 2 mode\*
5. Alarm, Zone Blank\*
  - Alarm resume\*
  - Alarm dwell sec\*
  - Alarm priority\*
  - Alarm pattern\*
  - Zone blank\*
6. Other
  - Auto flip
  - Proportional pan\*
  - Limit stops
  - Park time minutes
  - Scan speed deg/s
  - Pattern length\*

The following sections explain how to program the Spectra II™ and Spectra Lite™ domes using the menu choices.

## MAIN MENU ACCESS

You can call up the main menu on your monitor by programming (setting or creating) preset 95 (28 if in 32-preset mode; refer to the *Preset Functions* section).

Programming preset 95 for Pelco's controllers varies according to the type of controller you are using. Instructions for programming preset 95 are given below for various Pelco controllers.

### CM6700

1. Enter the number of the Spectra II™ or Spectra Lite™ camera and press the CAM key.
2. Enter 95 and hold the PRESET key for two seconds.
3. In the Edit Preset menu, arrow to SET and press the ACK key. The main menu appears.

### CM8500

1. Enter the number of the Spectra II™ or Spectra Lite™ camera and press the CAM key.
2. Highlight PRESET in the Camera menu and hold down the joystick button until the Set Presets prompt appears.
3. Enter 95 and press the PRESET key. The main menu appears.

### CM9500

1. Enter the number of the Spectra II™ or Spectra Lite™ camera and press the CAM key.
2. Press the SELECT key twice.
3. Highlight CAM in the Setup menu and press the SELECT key.
4. Highlight PRESET in the Camera menu and press the SELECT key.
5. Enter 95 and press the F1 key. The main menu appears.

### CM9750

1. Turn the KEY SWITCH to the ON position.
2. Press the PROG key. PROGRAM appears on the LCD display.
3. Press the PRES key. The PRESET prompt appears.
4. Enter 95 and press the ENTER key. The main menu appears.
5. Turn the KEY SWITCH to the OFF position.

### CM9760

1. In the default menu, select DEF. The Define Submenu appears.
2. Enter your four-digit PIN.
3. Enter 95 and select PRST. The main menu appears on the monitor.
4. Select the Quit icon to return to the default menu.

### MPT9500

#### Standard Coaxitron® Mode

1. Enter 95 and press the PRESET SET key.
2. Position the asterisk in the YES row and press the F1 key. The main menu appears.

#### Extended Coaxitron® or RS-485 Mode

1. Enter 95 and press the PRESET SET key.
2. Press the F2 key. The main menu appears.

## BACKLIGHT COMPENSATION

There are two backlight compensation modes: on and off.

Backlight compensation allows the Spectra II™ dome to compensate for bright light behind the object you want to view. With backlight compensation On, the Spectra II™ dome will use only the center 10 percent of the picture for adjusting the iris (refer to Figure 17). If there is a bright light source outside of this area, it will wash out to white. The camera will adjust the iris so that the object in the sensitive area is properly exposed.

To change the backlight compensation mode:

1. Program Preset 95 (28 if in 32-preset mode; refer to the *Preset Functions* section) to access the main menu (refer to the *Main Menu Access* section). The main menu will appear.
2. If the cursor (>) is not beside Camera, move the joystick up or down to position the cursor beside Camera.



**Figure 17.** Backlight Compensation

3. Press the Iris Open button to enter the Camera submenu.
4. Move the joystick up or down to position the cursor beside Backlight Comp.
5. Press the Iris Open button on your keyboard. A star will appear beside Backlight Comp and the cursor will move to the right beside the word On or Off.
6. Move the joystick up or down to toggle between On and Off.
7. SELECT - Press the Iris Open button on your keyboard to select your choice.  
CANCEL - Press the Iris Close button if you do not want to change the setting.

## ZOOM LIMIT

(This section applies to Spectra II™ only.)

The Spectra II™ dome can magnify an object up to 128 times. The dome has 16X of optical zoom and 8X of electronic (digital) zoom for 128X total zoom. The amount of zoom can be set for 16X, 32X, 64X, or 128X.

To change the zoom limit:

1. Program preset 95 (28 if in 32-preset mode; refer to the *Preset Functions* section) to access the main menu (refer to the *Main Menu Access* section). The main menu will appear.
2. If the cursor (>) is not beside Camera, move the joystick up or down to position the cursor beside Camera.
3. Press the Iris Open button to enter the Camera submenu.
4. Move the joystick up or down to position the cursor beside Zoom Limit.
5. Press the Iris Open button. A star will appear beside Zoom Limit and the cursor will move to the right beside the current zoom limit.
6. Move the joystick up or down to choose the zoom limit.
7. SELECT - Press the Iris Open button on your keyboard to select your choice.  
CANCEL - Press the Iris Close button if you do not want to change the setting.

## RESET CAMERA

Resetting the camera returns the following settings to their defaults. (An asterisk denotes items that apply to the Spectra II™ only.)

<u>Setting:</u>	<u>Default:</u>
Auto-focus mode*	Auto*
Gain/AGC	
AGC mode	Auto
Gain	No default setting
Backlight comp	Off
Shutter speed	Auto
Auto-iris	
Mode	Auto
Level	Default value depends on type of camera
Peak	Default value depends on type of camera
White balance	
Auto white balance	On
R-B white balance	No default setting
M-G white balance	No default setting
Sharpness	
Auto sharpness	On
Sharpness	No default setting

When the camera is reset, the following settings are not changed: park time, auto flip disable, limit stops; and for the Spectra II™ only, zoom limit and proportional panning.

Turning off power to the Spectra II™ and Spectra Lite™ domes does not reset the camera. Camera settings are retained in memory, and when the power is turned back on, the settings will be the same as they were when it was turned off.

To reset the camera:

1. Program preset 95 (28 if in 32-preset mode; refer to the *Preset Functions* section) to access the main menu (refer to the *Main Menu Access* section). The main menu will appear.
2. If the cursor (>) is not beside Camera, move the joystick up or down to position the cursor beside Camera.
3. Press the Iris Open button to enter the Camera submenu.
4. Move the joystick up or down to position the cursor beside Reset Camera.
5. Press the Iris Open button to reset the camera.

## GAIN/AGC

### AGC Mode

There are three AGC (Automatic Gain Control) modes: auto, on, and off.

In the auto mode, the Spectra II™ and Spectra Lite™ domes automatically adjust the gain—the amount of amplification the camera places on its video information in order to obtain a full 1-volt peak-to-peak video signal out. If the iris is manually opened to its wide-open position and the picture is weak, the AGC can be turned off and the gain increased manually to improve the picture. For instructions on how to do this, refer to the *Auto Iris* section. When you close the iris, the AGC will turn back on automatically when the lens iris starts closing.

In the on mode the AGC is on all the time.

In the off mode the AGC is off.

To change the AGC mode:

1. Program preset 95 (28 if in 32-preset mode; refer to the *Preset Functions* section) to access the main menu (refer to the *Main Menu Access* section). The main menu will appear.
2. If the cursor (>) is not beside Camera, move the joystick up or down to position the cursor beside Camera.
3. Press the Iris Open button to enter the Camera submenu.
4. Move the joystick up or down to position the cursor beside Gain/AGC.
5. Press the Iris Open button to enter the Gain/AGC submenu.
6. Move the joystick up or down to position the cursor beside AGC mode.
7. Press the Iris Open button on your keyboard. A star will appear beside AGC mode and the cursor will move to the right beside the word Auto, On, or Off.
8. Move the joystick up or down to position the cursor beside Auto, On, or Off.
9. SELECT - Press the Iris Open button on your keyboard to select your choice.  
CANCEL - Press the Iris Close button if you do not want to change the setting.

## Gain

The gain adjusts the signal level of the video output. Increasing the gain in low light conditions will increase the level of noise in the picture.

To change the gain:

1. Program preset 95 (28 if in 32-preset mode; refer to the *Preset Functions* section) to access the main menu (refer to the *Main Menu Access* section). The main menu will appear.
2. If the cursor (>) is not beside Camera, move the joystick up or down to position the cursor beside Camera.
3. Press the Iris Open button to enter the Camera submenu.
4. Move the joystick up or down to position the cursor beside Gain/AGC.
5. Press the Iris Open button to enter the Gain/AGC submenu.
6. Move the joystick up or down to position the cursor beside Gain.
7. Press the Iris Open button on your keyboard. A star will appear beside Gain and the cursor will move to the right beside the current gain setting (a numeric value).
8. Move the joystick up or down to change the gain. As you change the gain, the picture on your monitor will get brighter or darker.
9. SELECT - Press the Iris Open button on your keyboard to select your choice.  
CANCEL - Press the Iris Close button if you do not want to change the setting.

## AUTO IRIS

There are three settings for auto iris: mode, level, and peak.

To change the settings for auto iris:

1. Program preset 95 (28 if in 32-preset mode; refer to the *Preset Functions* section) to access the main menu (refer to the *Main Menu Access* section). The main menu will appear.
2. If the cursor (>) is not beside Camera, move the joystick up or down to position the cursor beside Camera.
3. Press the Iris Open button to enter the Camera submenu.
4. Move the joystick up or down to position the cursor beside Auto-Iris.
5. Press the Iris Open button on your keyboard. Another menu will appear with auto-iris mode, level, and peak selections.
6. Move the joystick up or down to position the cursor beside one of the choices. Press the Iris Open button on your keyboard.

MODE - The cursor moves to one of two choices: Auto or Off. In the Auto mode, the iris is automatically adjusted to produce a constant video output as determined by the Level setting below. In the Off mode, auto iris is disabled, and control is always manual. Move the joystick up or down to toggle between Auto and Off. Press the Iris Open button to select the choice, or press the Iris Close button if you do not want to change the setting.

LEVEL - The cursor moves to a numeric value, which the Spectra II™ dome uses to try to maintain a certain light level. Changing the value of the Level setting will change the video level to which the auto iris adjusts. This setting should be adjusted if the video level in the auto iris mode is too bright or too dark. Move the joystick up or down to a value. Press the Iris Open button to select the value, or press the Iris Close button if you do not want to change the setting.



PEAK - The cursor moves to a numeric value. Increasing this value will cause the auto iris circuit to react more to highlights or "peaks" in the picture. Decreasing this value will cause it to use the average video level to adjust the iris. Move the joystick up or down to a value. Press the Iris Open button to select the value, or press the Iris Close button if you do not want to change the setting.

If auto iris is in the auto mode, it remains that way until you manually open or close the iris. The dome will return to auto iris when it is panned or tilted more than 15 degrees.

If there is not enough light for a good picture when the iris is wide open, you can increase the gain of the camera to improve the picture. To do this:

1. The AGC mode (*AGC Mode* section) must be in either the Auto or Off mode. The following steps will not work if the AGC mode is On.
2. Hold down the Iris Open button until the iris is wide open.
3. Release the button.
4. Within one second, hold down the button again. This will start increasing the camera gain. Hold down the button until a desirable picture is obtained or the maximum gain is reached.

## SHUTTER SPEED

There are nine electronic shutter speed settings:

Auto  
1/100  
1/120  
1/500  
1/1000  
1/2000  
1/4000  
1/10,000  
1/30,000

In the Auto setting the camera controls the shutter speed automatically.

Increasing the shutter speed lowers the light sensitivity, but rapidly moving objects will be less blurred as the speed is increased.

To change the electronic shutter speed settings:

1. Program preset 95 (28 if in 32-preset mode; refer to the *Preset Functions* section) to access the main menu (refer to the *Main Menu Access* section). The main menu will appear.
2. If the cursor (>) is not beside Camera, move the joystick up or down to position the cursor beside Camera.
3. Press the Iris Open button to enter the Camera submenu.
4. Move the joystick up or down to position the cursor beside Next.
5. Press the Iris Open button to go to the next camera submenu.
6. Move the joystick up or down to position the cursor beside Shutter Speed.
7. Press the Iris Open button on your keyboard.
8. A star will appear beside Shutter Speed and the cursor will move to the right beside the current shutter speed.
9. Move the joystick up or down to choose the shutter speed.
10. SELECT - Press the Iris Open button on your keyboard to select your choice.  
CANCEL - Press the Iris Close button if you do not want to change the setting.

## AUTO-FOCUS MODE

(This section applies to Spectra II™ only.)

There are two auto-focus modes: auto and off.

If auto focus is in the auto mode, pressing the Focus Far or Focus Near button will place the focus in the manual mode. The dome will return to auto focus if you pan or tilt the unit or do a zoom function.

If the mode is set to off, the dome will operate in the manual mode with one exception. If you issue a command to go to a preset, auto focus will turn on and remain on until you press the Focus Far or Focus Near button.

To change the mode:

1. Program preset 95 (28 if in 32-preset mode; refer to the *Preset Functions* section) to access the main menu (refer to the *Main Menu Access* section). The main menu will appear.
2. If the cursor (>) is not beside Camera, move the joystick up or down to position the cursor beside Camera.
3. Press the Iris Open button to enter the Camera submenu.
4. Move the joystick up or down to position the cursor beside Next.
5. Press the Iris Open button to go to the next camera menu.
6. Move the joystick up or down to position the cursor beside Auto-Focus Mode.
7. Press the Iris Open button on your keyboard. A star will appear beside Auto-Focus Mode and the cursor will move to the right beside the word Auto or Off.
8. Move the joystick up or down to toggle between Auto and Off.
9. SELECT - Press the Iris Open button on your keyboard to select your choice.  
CANCEL - Press the Iris Close button if you do not want to change the setting.

## SHARPNESS

There are two modes for adjusting the sharpness of the picture: automatic and manual.

To change the mode:

1. Program preset 95 (28 if in 32-preset mode; refer to the *Preset Functions* section) to access the main menu (refer to the *Main Menu Access* section). The main menu will appear.
2. If the cursor (>) is not beside Camera, move the joystick up or down to position the cursor beside Camera.
3. Press the Iris Open button to enter the Camera submenu.
4. Move the joystick up or down to position the cursor beside Next.
5. Press the Iris Open button to go to the next camera menu.
6. Move the joystick up or down to position the cursor beside Sharpness.
7. Press the Iris Open button. Another menu will appear with the auto sharpness and sharpness selections.
8. Move the joystick up or down to position the cursor beside one of the choices. Press the Iris Open button.

AUTO SHARPNESS - The cursor moves to one of two choices: On or Off. Move the joystick up or down to toggle between them. Press the Iris Open button to select the choice, or press the Iris Close button if you do not want to change the setting.

SHARPNESS - The cursor moves to a numeric value. Move the joystick up or down to a value. As you change the value, you will see the sharpness change. Press the Iris Open button to select the value, or press the Iris Close button if you do not want to change the setting. If the Auto Sharpness is on, it will change to off when you select a new value.

## WHITE BALANCE (COLOR CAMERAS ONLY)

There are three settings for white balance: auto, red-blue, and magenta-green.

To change the white balance settings:

1. Program preset 95 (28 if in 32-preset mode; refer to the *Preset Functions* section) to access the main menu (refer to the *Main Menu Access* section). The main menu will appear.
2. If the cursor (>) is not beside Camera, move the joystick up or down to position the cursor beside Camera.
3. Press the Iris Open button to enter the Camera submenu.
4. Move the joystick up or down to position the cursor beside Next.
5. Press the Iris Open button to go to the next camera submenu.
6. Move the joystick up or down to position the cursor beside White Balance.
7. Press the Iris Open button on your keyboard. Another menu will appear with the auto, red-blue, and magenta-green selections.
8. Move the joystick up or down to position the cursor beside one of the choices. Press the Iris Open button on your keyboard.

AUTO WHITE BALANCE - The cursor moves to one of two choices: Auto or Off. Move the joystick up or down to toggle between them. Press the Iris Open button to select the choice, or press the Iris Close button if you do not want to change the setting.

R-B WHITE BALANCE - The cursor moves to a numeric value. Move the joystick up or down to a value. As you change the value, you will see the color change on your monitor. Press the Iris Open button to select the value, or press the Iris Close button if you do not want to change the setting. If Auto White Balance is on, it will change to off when you select a new value.

M-G WHITE BALANCE - The cursor moves to a numeric value. Move the joystick up or down to a value. As you change the value, you will see the color change on your monitor. Press the Iris Open button to select the value, or press the Iris Close button if you do not want to change the setting. If Auto White Balance is on, it will change to off when you select a new value.

## LINE SYNCHRONIZATION

(This section applies to Spectra II™ only.)

You can turn the line synchronization on or off.

If it is on, you can adjust the synchronization of the power line voltage so that it is in phase with other cameras. If cameras are out of phase with each other, they may produce what appears to be vertical roll when switching between cameras.

If it is off, the dome synchronizes to an internal clock.

To change the line synchronization settings:

1. Program preset 95 (28 if in 32-preset mode; refer to the *Preset Functions* section) to access the main menu (refer to the *Main Menu Access* section). The main menu will appear.

2. If the cursor (>) is not beside Line Sync, move the joystick up or down to position the cursor beside Line Sync.
3. Press the Iris Open button on your keyboard. Another menu will appear with the Line Sync and Line Sync Phase selections.
4. Move the joystick up or down to position the cursor beside one of the choices.

LINE SYNC - The cursor moves to one of two choices: On or Off. Move the joystick up or down to toggle between them.

Press the Iris Open button to select the choice. If you changed to Off, the camera may reset itself as it adjusts to the new synchronization. If the camera resets, it will only affect the line synchronization. It will *not* change any other camera parameters, such as auto focus or auto iris.

Press the Iris Close button if you do not want to change the setting.

LINE SYNC PHASE - The cursor moves to a numeric value. Move the joystick up or down to change the value.

Press the Iris Open button to select the choice. The value represents the phase angle in tenths of a degree between 0 degrees and 359 degrees. For example, 900 is 90 degrees, 1200 is 120 degrees, and 2400 is 240 degrees. Press the Iris Open button on your keyboard to select your choice. The Line Sync setting will change to On. The camera may reset or the picture on your monitor may wiggle when you change the phase angle. If the camera resets, it will only affect the line synchronization. It will *not* change any other camera parameters, such as auto focus or auto iris.

Press the Iris Close button if you do not want to change the setting.

## POWER-UP MODE

This feature lets the dome resume a desired condition following power-up. The menu includes the following choices. (An asterisk denotes items that apply to the Spectra II™ only.)

- Default – On power-up, the dome goes through a configuration cycle and stops at zero reference, showing "Configuration Done," and address and mode settings on the screen.
- Park – The dome moves to preset 1 when the power-up sequence finishes. The only text on the screen is the preset label (if any is programmed).
- Scan Auto – The dome initiates scan mode when the power-up sequence finishes. Again, there is no text.
- Scan Frame – The dome initiates a frame scan when the power-up sequence finishes.
- Scan Rand – The dome initiates a random scan when the power-up sequence finishes.
- Full Pat\* – The dome initiates its programmed pattern when the power-up sequence finishes. The length can be set to 1.5, 3, or 6 minutes.
- Half Pat 1\* – The dome initiates the first half-pattern when the power-up sequence finishes. The length can be set to .75, 1.5, or 3 minutes.
- Half Pat 2\* – The dome initiates the second half-pattern when the power-up sequence finishes. The length can be set to .75, 1.5, or 3 minutes.

The default setting is Default.

To select the power-up mode:

1. Program preset 95 (28 if in 32-preset mode; refer to the *Preset Functions* section) to access the main menu (refer to the *Main Menu Access* section). The main menu will appear.
2. If the cursor (>) is not beside Power Up Mode, move the joystick up or down to position the cursor beside Power Up Mode.
3. Press the Iris Open button to enter the Power Up Mode submenu.
4. Move the joystick up or down to cycle through the selections. Stop on the item you want to select.
5. SELECT - Press the Iris Open button on your keyboard to select your choice.  
CANCEL - Press the Iris Close button if you do not want to change the setting.

## AUX MODE

(This section applies to Spectra II™ only.)

This feature defines the output relay as either Normal (under control of the head end), Latching (pressing the AUX key turns on the AUX and the next press of the AUX key turns it off), or Alarm (any alarm input activates the AUX).

To change the AUX mode:

1. Program preset 95 (28 if in 32-preset mode; refer to the *Preset Functions* section) to access the main menu (refer to the *Main Menu Access* section). The main menu will appear.
2. If the cursor (>) is not beside AUX, move the joystick up or down to position the cursor beside AUX.
3. Press the Iris Open button to enter the AUX submenu.
4. Move the joystick up or down to position the cursor next to either Aux 1 mode or Aux 2 mode.
5. Press the Iris Open button. The cursor will move to the right beside the word Normal, Latching, or Alarm.
6. Move the joystick up or down to toggle between Normal, Latching, or Alarm.
7. SELECT - Press the Iris Open button on your keyboard to select your choice.  
CANCEL - Press the Iris Close button if you do not want to change the setting.

## ALARM RESUME

(This section applies to Spectra II™ only.)

This mode lets the dome resume its previous activity (scan, pattern, or previous position) after all alarms are cleared.

To change the alarm resume mode:

1. Program preset 95 (28 if in 32-preset mode; refer to the *Preset Functions* section) to access the main menu (refer to the *Main Menu Access* section). The main menu will appear.
2. If the cursor (>) is not beside Alarms, Zone Blank, move the joystick up or down to position the cursor beside Alarms, Zone Blank.
3. Press the Iris Open button to enter the Alarms, Zone Blank submenu.
4. Move the joystick up or down to position the cursor beside Alarm Resume.
5. Press the Iris Open button. The cursor will move to the right beside the word On or Off.

6. Move the joystick up or down to toggle between On or Off.
7. SELECT - Press the Iris Open button on your keyboard to select your choice.  
CANCEL - Press the Iris Close button if you do not want to change the setting.

## ALARM DWELL

(This section applies to Spectra II™ only.)

This is the minimum time the Spectra II™ will stay at an alarm even if the alarm is present for less than this amount of time.

To change the alarm dwell:

1. Program preset 95 (28 if in 32-preset mode; refer to the *Preset Functions* section) to access the main menu (refer to the *Main Menu Access* section). The main menu will appear.
2. If the cursor (>) is not beside Alarms, Zone Blank, move the joystick up or down to position the cursor beside Alarms, Zone Blank.
3. Press the Iris Open button to enter the Alarms, Zone Blank submenu.
4. Move the joystick up or down to position the cursor beside Alarm Dwell sec.
5. Press the Iris Open button. The cursor will move to the right beside the number of seconds for the alarm dwell time.
6. Move the joystick up or down and hold to cycle through 1-200 seconds in one-second increments.
7. SELECT - Press the Iris Open button on your keyboard to select your choice.  
CANCEL - Press the Iris Close button if you do not want to change the setting.

## ALARM PRIORITY

(This section applies to Spectra II™ only.)

This feature lets you set alarm inputs as either high or low priority. A high priority alarm will not release to a low priority alarm. Alarms will release or sequence between low priority alarms only if no high priority alarm exists. (Refer to the *Alarms* section for more information.)

To change alarm priority:

1. Program preset 95 (28 if in 32-preset mode; refer to the *Preset Functions* section) to access the main menu (refer to the *Main Menu Access* section). The main menu will appear.
2. If the cursor (>) is not beside Alarms, Zone Blank, move the joystick up or down to position the cursor beside Alarms, Zone Blank.
3. Press the Iris Open button to enter the Alarms, Zone Blank submenu.
4. Move the joystick up or down to position the cursor beside Alarm Priority.
5. Press the Iris Open button to enter the Alarm Priority submenu.
6. Move the joystick up or down to position the cursor beside the number of the alarm input for which you want to set the priority.
7. Press the Iris Open button. The cursor will move to the right beside the word High or Low.
8. Move the joystick up or down to toggle between the words High and Low.
9. SELECT - Press the Iris Open button on your keyboard to select your choice.  
CANCEL - Press the Iris Close button if you do not want to change the setting.

*NOTE: Pattern length is set on the secondary menu entitled Other.*

*NOTE: To make the pattern run to its end when an alarm activates it, make alarm dwell time longer than pattern length. Therefore, if the alarm goes away before the end of the pattern, the pattern will continue until the dwell times out.*

## ALARM PATTERN

(This section applies to Spectra II™ only.)

In response to an alarm, the Spectra II™ dome can do either one full pattern (1.5, 3, or 6 minutes long) or two half patterns (.75, 1.5, or 3 minutes long). You can choose one of the following for each of the seven alarm inputs:

- Full Pat (run full pattern)
- Half Pat 1 (run half pattern 1)
- Half Pat 2 (run half pattern 2)
- No Pattern

To change the alarm pattern:

1. Program preset 95 (28 if in 32-preset mode; refer to the *Preset Functions* section) to access the main menu (refer to the *Main Menu Access* section). The main menu will appear.
2. If the cursor (>) is not beside Alarms, Zone Blank, move the joystick up or down to position the cursor beside Alarms, Zone Blank.
3. Press the Iris Open button to enter the Alarms, Zone Blank submenu.
4. Move the joystick up or down to position the cursor beside Alarm Pattern.
5. Press the Iris Open button to enter the Alarm Pattern submenu.
6. Move the joystick up or down to position the cursor beside the number of the alarm input for which you want to set the pattern.
7. Press the Iris Open button. The cursor will move to the right beside the words Full Pat, Half Pat 1, Half Pat 2, or No Pattern.
8. Move the joystick up or down to toggle between the choices.
9. SELECT - Press the Iris Open button on your keyboard to select your choice.  
CANCEL - Press the Iris Close button if you do not want to change the setting.

## ZONE BLANK

(This section applies to Spectra II™ only.)

This feature lets you define any of eight zones as blanked for video when the camera pans into the zone area. The choices are On and Off. On means video blanking is in effect. The default is Off.

To change the blank zone setting:

1. Program preset 95 (28 if in 32-preset mode; refer to the *Preset Functions* section) to access the main menu (refer to the *Main Menu Access* section). The main menu will appear.
2. If the cursor (>) is not beside Alarms, Zone Blank, move the joystick up or down to position the cursor beside Alarms, Zone Blank.
3. Press the Iris Open button to enter the Alarms, Zone Blank submenu.
4. Move the joystick up or down to position the cursor beside Zone Blank.
5. Press the Iris Open button to enter the Zone Blank submenu.
6. Move the joystick up or down to position the cursor beside the number of the zone for which you want to set the blank option.
7. Press the Iris Open button. The cursor will move to the right beside the word On or Off.
8. Move the joystick up or down to toggle between the words On and Off.
9. SELECT - Press the Iris Open button on your keyboard to select your choice.  
CANCEL - Press the Iris Close button if you do not want to change the setting.

## AUTO FLIP

There are two auto flip modes: on or off.

When the auto flip mode is on, the auto flip feature is enabled. When it is off, the feature is disabled.

To change the auto flip mode:

1. Program preset 95 (28 if in 32-preset mode; refer to the *Preset Functions* section) to access the main menu (refer to the *Main Menu Access* section). The main menu will appear.
2. If the cursor (>) is not beside Other, move the joystick up or down to position the cursor beside Other.
3. Press the Iris Open button to enter the Other submenu.
4. Move the joystick up or down to position the cursor beside Auto Flip.
5. Press the Iris Open button. A star will appear beside Auto Flip and the cursor will move to the right beside the word On or Off.
6. Move the joystick up or down to toggle between On and Off.
7. SELECT - Press the Iris Open button on your keyboard to select your choice.  
CANCEL - Press the Iris Close button if you do not want to change the setting.

## PROPORTIONAL PAN

(This section applies to Spectra II™ only.)

There are two proportional pan modes: on or off.

When proportional pan mode is on, the proportional pan feature is enabled and the pan (and tilt) speed will depend on the amount of zoom. At telephoto zoom settings, the pan (and tilt) speeds will be slower for a given amount of joystick deflection than at wide zoom settings. This keeps the image from moving too fast on the monitor when there is a large amount of zoom. This slowing does not happen when going to a preset, but does occur in turbo mode when high zoom is selected.

When the proportional pan mode is off, the feature is disabled and the pan speed will not depend on the amount of zoom.

To change the proportional pan mode:

1. Program preset 95 (28 if in 32-preset mode; refer to the *Preset Functions* section) to access the main menu (refer to the *Main Menu Access* section). The main menu will appear.
2. If the cursor (>) is not beside Other, move the joystick up or down to position the cursor beside Other.
3. Press the Iris Open button to enter the Other submenu.
4. Move the joystick up or down to position the cursor beside Proportional Pan.
5. Press the Iris Open button. A star will appear beside Proportional Pan and the cursor will move to the right beside the word On or Off.
6. Move the joystick up or down to toggle between On and Off.
7. SELECT - Press the Iris Open button on your keyboard to select your choice.  
CANCEL - Press the Iris Close button if you do not want to change the setting.



## LIMIT STOPS

There are two types of limit stops:

- Manual limit stops
- Scan limit stops

When manual limit stops are set, a manual (joystick) pan operation will stop when a limit stop is reached.

When scan limit stops are set, the dome will reverse direction during random, frame, or auto scanning when a limit stop is reached.

Limit stops are controlled by software. To set limit stops:

1. Turn on the limit stop mode.
2. Program the limit stops.

### Turning Limit Stops On or Off

To change the limit stop mode:

1. Program preset 95 (28 if in 32-preset mode; refer to the *Preset Functions* section) to access the main menu (refer to the *Main Menu Access* section). The main menu will appear.
2. If the cursor (>) is not beside Other, move the joystick up or down to position the cursor beside Other.
3. Press the Iris Open button to enter the Other submenu.
4. Move the joystick up or down to position the cursor beside Limit Stops.
5. Press the Iris Open button. A star will appear beside Limit Stops and the cursor will move to the right beside the word On or Off.
6. Move the joystick up or down to toggle between On and Off.
7. SELECT - Press the Iris Open button on your keyboard to select your choice.  
CANCEL - Press the Iris Close button if you do not want to change the setting.

### Programming Limit Stops

#### MANUAL LIMIT STOPS

Refer to the documentation for your control system for programming presets, then do the following:

1. Make sure limit stops are turned ON (refer to the *Limit Stops* section), then exit the menu.
2. Push the joystick left until you reach the limit you want the camera to go to on the left.
3. Program preset 90 (23).
4. Push the joystick right to the limit you want the camera to go to on the right.
5. Program preset 91 (24).

Setting presets 90 (23) and 91 (24) to the same point disables manual limit stops.

#### SCAN LIMIT STOPS

Refer to the documentation for your control system for programming presets, then do the following:

1. Make sure limit stops are turned ON (refer to the *Limit Stops* section), then exit the menu.
2. Push the joystick left until you reach the limit you want the camera to go to on the left.
3. Program preset 92 (25).
4. Push the joystick right to the limit you want the camera to go to on the right.
5. Program preset 93 (26).

Setting presets 92 (25) and 93 (26) to the same point disables scan limit stops.

*NOTE: Programming preset 90 (23) disables the manual limit stops until preset 91 (24) is set.*

*NOTE: On power-up, the auto scan tilt angle will be whatever angle the camera was at when the right scan limit was set.*

*NOTE: Preset 1 must be programmed for the dome to park.*

## PARK TIME MINUTES

This feature causes the dome to park at preset 1 after a programmed number of minutes of control inactivity. The time can be set from 1 minute to 720 minutes (12 hours), or it can be set to zero, which disables this feature.

To change the park time:

1. Program preset 95 (28 if in 32-preset mode; refer to the *Preset Functions* section) to access the main menu (refer to the *Main Menu Access* section). The main menu will appear.
2. If the cursor (>) is not beside Other, move the joystick up or down to position the cursor beside Other.
3. Press the Iris Open button to enter the Other submenu.
4. Move the joystick up or down to position the cursor beside Park Time Minutes.
5. Press the Iris Open button. A star will appear beside Park Time Minutes and the cursor will move to the right beside the current park time.
6. Move the joystick up or down to change the park time.
7. SELECT - Press the Iris Open button on your keyboard to select your choice.  
CANCEL - Press the Iris Close button if you do not want to change the setting.

## SCAN SPEED

The scan speed is adjustable from 1-40 degrees per second. This occurs in three scan modes: auto, random, and frame scan.

To change the scan speed:

1. Program preset 95 (28 if in 32-preset mode; refer to the *Preset Functions* section) to access the main menu (refer to the *Main Menu Access* section). The main menu will appear.
2. If the cursor (>) is not beside Other, move the joystick up or down to position the cursor beside Other.
3. Press the Iris Open button to enter the submenu entitled Other.
4. Move the joystick up or down to position the cursor beside Scan Speed deg/s.
5. Press the Iris Open button. The cursor will move to the right beside the number of degrees.
6. Move the joystick up or down to toggle through the number of degrees (1-40) until you reach the number you want. (If set on a low number, the scan will appear to barely move but is still functioning.)
7. SELECT - Press the Iris Open button on your keyboard to select your choice.  
CANCEL - Press the Iris Close button if you do not want to change the setting.

## PATTERN LENGTH

(This section applies to Spectra II™ only.)

You can set the pattern length to 1.5, 3, or 6 minutes or have two half-patterns of .75, 1.5, or 3 minutes long.

To set the pattern length:

1. Program preset 95 (28 if in 32-preset mode; refer to the *Preset Functions* section) to access the main menu (refer to the *Main Menu Access* section). The main menu will appear.
2. If the cursor (>) is not beside Other, move the joystick up or down to position the cursor beside Other.



**CAUTION:** *If the length is changed, all patterns that were stored are erased.*

3. Press the Iris Open button to enter the submenu entitled Other.
4. Move the joystick up or down to position the cursor beside Pattern Length.
5. Press the Iris Open button. The cursor will move to the right beside the number of minutes (1.5, 3, or 6).
6. Move the joystick up or down to toggle through the number of minutes (1.5, 3, or 6).
7. SELECT - Press the Iris Open button on your keyboard to select your choice.  
CANCEL - Press the Iris Close button if you do not want to change the setting.

## TROUBLESHOOTING

*NOTE: The dome drive contains no user-serviceable parts. If there is a problem with your dome drive, it must be returned to Pelco as a complete unit for servicing.*

Symptom: Unit does not operate.

1. Make sure your controller is trying to communicate with the unit and not another camera.
2. Turn off power.
3. Remove the lower dome:
 

In-Ceiling Models - Insert the flat blade of a screwdriver into one of the slots on the trim ring and twist the screwdriver to pop loose the trim ring and lower dome.

Pendant Models - Remove the two screws that hold the trim ring to the back box. Insert the flat blade of a screwdriver into the slots on the trim ring and twist the screwdriver to free the lower dome from the back box.
4. Remove the dome drive: Push in on the green drive eject tab on the side of the dome drive and gently rock the dome drive to release the latch. When the green latch releases, pull the dome down.
5. Turn on power.
6. If the red power LED on the door of the interconnect circuit board in the back box does not light, turn off power.
  - a. Open the door to the interconnect circuit board and check the fuse. Refer to Figure 12 or 13 for the location of the fuse. If the fuse is bad, replace it. To order a replacement fuse from Pelco, specify the part number FUS1.6-5X20FAST. This is a 1.6-ampere fuse, 5 x 20 mm, fast blow.
  - b. If the fuse is good, turn on power and use a voltmeter to check if 24 VAC is getting to the power connector on the interconnect circuit board. Refer to Figure 12 or 13 for the location of the AC power connector.
  - c. If there is 24 VAC to the power connector, turn off power and return the back box electronic assembly to the factory for repair. Refer to the *Back Box Electronic Assembly Removal* section.
  - d. If there is no voltage at the power connector, check your power supply.
7. If the red power LED is lit, turn off power.
  - a. Open the door to the interconnect circuit board and check that all connectors are fully seated.
  - b. Make sure the wiring is correct between the unit and controller.
  - c. Close the door. Check the switch settings on the dome drive (refer to Tables C, D, and E) and reinstall the dome drive.

- d. Turn on power. If the unit still does not operate, turn off power and replace the dome drive with a unit that is good, if you have a spare. Check the switch settings on the substitute dome drive before installing it. If you do not have a spare, return the dome drive to the factory. Also return the back box electronic assembly. Refer to the *Back Box Electronic Assembly Removal* section.
- e. If you substituted a dome drive, turn on power. If the unit operates, the original dome drive is bad. Return it to the factory. If the unit still does not operate, then the interconnect board is bad. Return the back box electronic assembly to the factory; refer to the *Back Box Electronic Assembly Removal* section.

Symptom: Fan does not operate.

1. Turn off power.

2. Remove the lower dome:

In-Ceiling Models - Insert the flat blade of a screwdriver into one of the slots on the trim ring and twist the screwdriver to pop loose the trim ring and lower dome.

Pendant Models - Remove the two screws that hold the trim ring to the back box. Insert the flat blade of a screwdriver into the slots on the trim ring and twist the screwdriver to free the lower dome from the back box.

3. Remove the dome drive: Push in on the green drive eject tab on the side of the dome drive and gently rock the dome drive to release the latch. When the green latch releases, pull the dome down.
4. Make sure the connector for the fan is fully seated.
5. Replace the dome drive. Turn on power. If the fan does not operate, return the back box electronic assembly and dome drive to the factory for repair. Refer to the *Back Box Electronic Assembly Removal* section.

Symptom: Alarms not cycling when more than one alarm is active  
Reset all your alarm priorities to all LOW or all HIGH (refer to the *Alarms* section for an explanation of alarm high/low priorities). To reset the alarm priorities, do the following:

1. Go to the *Main Menu Access* section and follow the instructions for accessing the programming main menu.
2. Go to the *Alarm Priority* section and follow the instructions for setting the alarm priority.

Symptom: Alarms not going to preset

1. Check that the preset is defined.
2. Check that no higher priority alarm is activated.
3. Check that a pattern is not set for the affected alarm(s). If a pattern is set, the alarm will run a pattern, not go to a preset. If a pattern (or patterns) is set, reset the pattern(s) to NO PATTERN.

To reset a pattern, do the following:

1. Go to the *Main Menu Access* section and follow the instructions for accessing the programming main menu.
2. Go to the *Alarm Pattern* section and follow the instructions for setting the alarm pattern.

Symptom: Alarms not starting a pattern

Ensure that the pattern selected is valid. Any time you expect a pattern to execute, make sure the pattern is recorded correctly and is valid.

Symptom: Motion problems

When troubleshooting motion problems on a system where alarms are connected, you can eliminate alarms as a cause of the problem by disconnecting the alarm block in the back box.

## BACK BOX ELECTRONIC ASSEMBLY REMOVAL

To remove the back box electronic assembly:

1. Turn off power.
2. Open the interconnect door and disconnect all wiring to the back box.
3. Use an 11/32 socket driver to remove the three 8-32 washers and nuts that hold the electronic assembly to the back box. When the screws are removed, the interconnect back box receptacle will drop down. It may be necessary to move the open interconnect door past 90 degrees vertical toward the side of the back box to release the door from the built-in grounding strip (and free the interconnect back box receptacle).
4. Remove the interconnect back box receptacle with the electronic components from the back box.

## MAINTENANCE

### DOME CLEANING

Clean the acrylic dome as necessary to maintain a clear picture. Be careful not to scratch the surfaces of the dome.

Exterior Surface - Clean the dome's exterior surface with a nonabrasive cleaning cloth and cleaning agent that is safe for acrylic. Either liquid or spray cleaner/wax suitable for fine furniture is acceptable.

Interior Surface (Except Chrome or Gold) - Clean the same as the exterior surface.

Interior Surface (Chrome or Gold) - The inside surface of a chrome or gold dome is easily scratched. Use the following precautions to maintain the dome's surface.

- a. Always handle the dome from the outside of its circular flange.
- b. Never touch the coated inside surface. The acid in your fingerprints will eventually etch the coating if the fingerprints are not carefully removed according to the recommended cleaning procedure in item "e".
- c. If dust or other contaminants accumulate on the dome's interior, remove the debris with compressed air. Compressed air cans are available from photographic equipment or electronic supply dealers.
- d. If heavy residue accumulates and cannot be removed with air pressure, rinse with water and immediately dry with air pressure so that water spots will not remain. Avoid wiping the coated surface with direct hand pressure - it will easily abrade unless extreme care is taken. Once scratched, the dome cannot be recoated.
- e. If internal wiping is necessary, avoid hand rubbing. Instead, make a wick as follows:

Use a very soft paper towel. Roll a section into a tightly wound tube. Tear the tube in half, and wet the fuzzy end of the wick with a solution of isopropyl alcohol diluted with water. Hold the dome with its opening facing downward and wipe the interior of the dome with the wet end of the wick. Use a circular motion, starting from the outside and spiraling into the center. Use a new wick for each two passes over the dome.

### SERVICE MANUAL

If you need to service your unit, obtain a service manual in one of the following ways:

- Go to Pelco's web site at <ftp://www.pelco.com> and find service manual C1455SM-B.
- Call Pelco's DataFAX service at 1-559-292-0435 and request document 214558.
- Contact Pelco's Literature Department and request service manual C1455SM-B.

# SPECIFICATIONS

## MECHANICAL

Construction	
Back box:	Aluminum
Dome drive:	Aluminum, ABS plastic
Lower dome:	Acrylic
Cable Entry	
In-Ceiling:	.75" (1.91 cm) conduit fitting
Pendant:	Through 1.5" (3.81 cm) NPT pendant mount
Pan Movement:	360° Continuous pan rotation
Vertical Tilt:	Unobstructed +2° to -92°
Manual Pan/Tilt Speeds*	
Pan:	0.5°-80°/sec manual operation, 150°/sec turbo
Tilt:	0.5°-40°/sec
Preset Speeds	
Pan:	250°/sec
Tilt:	200°/sec

\* For variable-speed operation an appropriate controller is required. With fixed-speed controllers, Spectra II™ and Spectra Lite™ pan speed is 30°/sec and tilt speed is 12°/sec. The CM6700 controller with the KBD200 keyboard has programmable fixed speeds.

## ELECTRICAL

Input Voltage:	18-30 VAC, 24 VAC nominal	
Input Power		
In-ceiling:	30 vA	
Indoor pendant:	30 vA	
Outdoor pendant:	75 vA	
Fuse:	1.6 A	
Relay Contacts	<u>AUX 1</u>	<u>AUX 2 Output</u>
Type:	Form C	Open collector transistor output
Voltage:	Low voltage (<40 V)	32 VDC maximum
Current:	2 A maximum	150 mA maximum

## GENERAL

Environment	
In-Ceiling:	Indoor only
Pendant:	Indoor/outdoor
Operating Range	
In-Ceiling:	32° to 140°F (0° to 60°C) intermittent operation; 32° to 122°F (0° to 50°C) continuous operation
Pendant	
Without Heater:	32° to 140°F (0° to 60°C) absolute maximum operating temperature; 32° to 122°F (0° to 50°C) sustained maximum operating temperature
With Heater*:	(Assumes no wind chill factor; for detailed test conditions, contact Pelco.) <u>Maximum operating temperature:</u> 140°F (60°C) absolute maximum; 122°F (50°C) sustained maximum <u>Minimum operating temperature:</u> -60°F (-51.11°C) absolute minimum; minimal icing at -50°F (-45.56°C) sustained minimum; prevents icing at -40°F (-40°C) sustained minimum; de-ices .1 inch (2.5 mm) within 3 hours after power-up
Dimensions:	See Figure 18

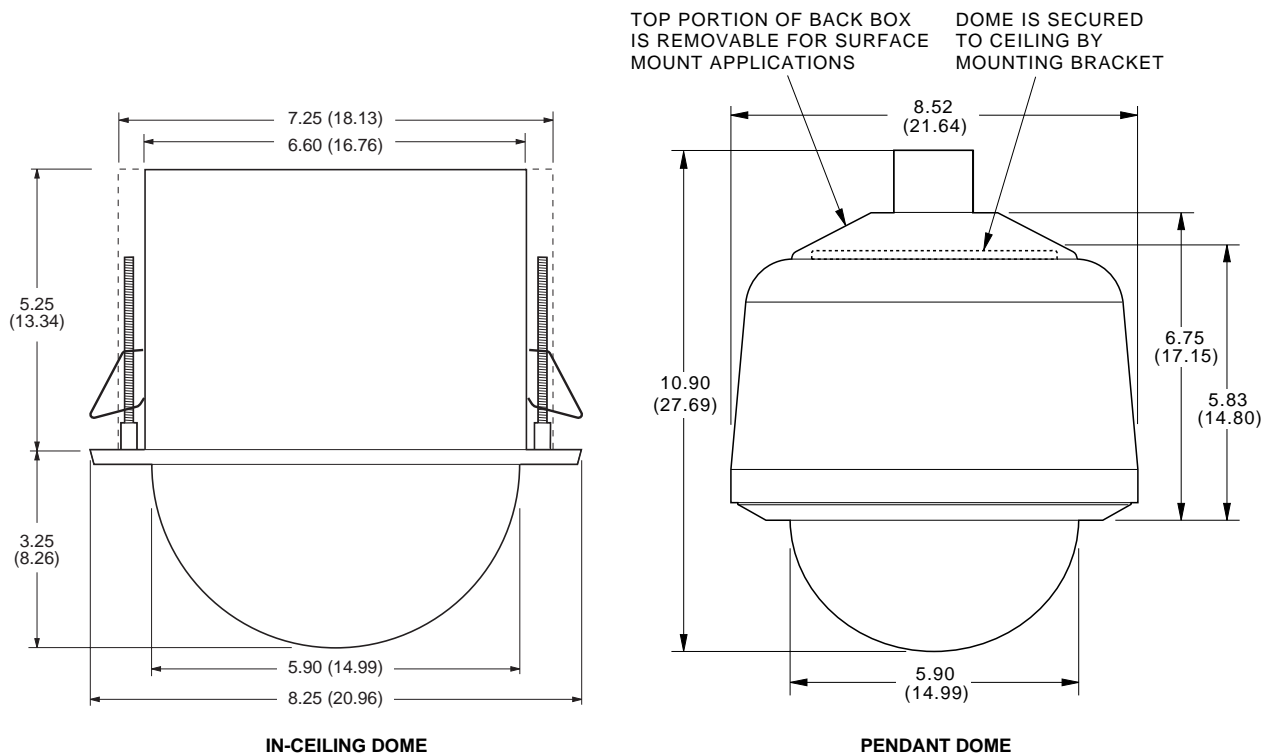

NOTE: VALUES IN PARENTHESES ARE CENTIMETERS; ALL OTHERS ARE INCHES.

**Figure 18.** SD5 Series Dimension Drawing

Ratings: NEMA Type 1–In-ceiling back boxes, all dome drives  
 NEMA Type 4–Pendant back boxes  
 IP 66–Pendant back boxes

Weight	Unit	Shipping
<b>In-Ceiling</b>		
Back Box:	2.6 lb (1.18 kg)	4 lb (1.81 kg)
Dome Drive:	2.65 lb (1.20 kg)	5 lb (2.27 kg)
Lower Dome:	.19 lb (.09 kg)	1 lb (.45 kg)
<b>Pendant</b>		
Back Box:	2.85 lb (1.28 kg)	5 lb (2.27 kg)
	<i>Add 1.25 lbs (.57 kg) for heater and sun shield</i>	
Dome Drive:	2.65 lb (1.20 kg)	5 lb (2.27 kg)
Lower Dome:	1.30 lb (.59 kg)	2.20 lb (1.0 kg)
	<i>Add .25 lbs (.11 kg) for heater</i>	

\* Assumes no wind chill factor; for detailed test conditions, contact Pelco.

CAMERAS

COLOR (Spectra II™ and Spectra Lite™)

Signal Format: NTSC (Spectra II™ model DD5AC)  
 PAL (Spectra II™ model DD5AC-X)  
 NTSC (Spectra Lite™ model DD5T-C)  
 PAL (Spectra Lite™ model DD5T-C-X)

Scanning System: 2:1 interlace

Image Sensor: 1/4-inch interline transfer CCD

Effective Pixels	
(NTSC Spectra II™):	768 (H) x 494 (V)
(PAL Spectra II™):	752 (H) x 582 (V)
(NTSC Spectra Lite™):	510 (H) x 492 (V)
(PAL Spectra Lite™):	500 (H) x 582 (V)
Horizontal Resolution	
(Spectra II™):	>450 TV lines
(Spectra Lite™):	>330 TV lines
Lens	
Minimum f-stop	
(Spectra II™):	F1.4
(NTSC Spectra Lite™):	F1.6-2.8
(PAL Spectra Lite™):	F1.6-2.5
Focal Length	
(Spectra II™):	4 mm to 64 mm optical
(Spectra Lite™):	4 mm to 48 mm optical
Zoom Ratio	
(Spectra II™):	16X optical zoom, 8X electronic zoom
(Spectra Lite™):	12X optical zoom
Horizontal Angle of View	
(Spectra II™):	47° (at 4 mm wide zoom), 3° (at 64 mm telephoto zoom)
(Spectra Lite™):	47° (at 4 mm wide zoom), 4° (at 48 mm telephoto zoom)
MTBF:	>2 million cycles at room temperature (zoom, focus, iris)
Focus	
(Spectra II™):	Automatic and manual override
(Spectra Lite™):	Manual with capability to focus when going to a preset position
Sensitivity	
(Spectra II™ NTSC):	1.5 lux at f1.4 at signal level of 40 IRE (NTSC), gain 22.0 dB
(Spectra II™ PAL):	1.5 lux at f1.4 at 300 mV, gain 24.7 dB
(Spectra Lite™ NTSC):	4 lux at f1.6 at signal level of 40 IRE (NTSC), gain high
(Spectra Lite™ PAL):	3 lux at f1.6 at 300 mV
Signal Process:	DSP-3R
Sync System	
(Spectra II™):	AC line lock, phase adjustable via remote control*
(Spectra Lite™):	Internal
White Balance:	Automatic with manual override*
Shutter Speed	Automatic (electronic iris)/manual
(Spectra II™ NTSC):	1/60-1/30,000*
(Spectra II™ PAL):	1/50-1/30,000*
(Spectra Lite™ NTSC):	1/100-1/30,000*
(Spectra Lite™ PAL):	1/100-1/30,000*
Iris Control:	
(Spectra II™):	Automatic with manual override*
(Spectra Lite™):	Automatic with manual override*
Gain Control:	Automatic with manual override*
Video Output	
(NTSC):	.714V ± .07V (100 IRE ± 10 IRE)
(PAL):	.7V ± .07V
Signal to Noise Ratio:	>46 dB



MONOCHROME (Spectra II™ Only)

Signal Format	EIA (model DD5AM) CCIR (model DD5AM-X)
Scanning System:	2:1 interlace
Image Sensor	1/4-inch interline transfer CCD
Horizontal Resolution:	>500 TV lines
Effective Pixels	
EIA:	768 (H) x 494 (V)
CCIR:	752 (H) x 582 (V)
Lens:	
Minimum f-stop:	F1.4
Focal Length:	4 mm to 64 mm optical
Zoom Ratio:	16X optical zoom, 8X electronic zoom
Horizontal Angle of View	47° (at 4 mm wide zoom), 3° (at 64 mm telephoto zoom)
MTBF:	>2 million cycles at room temperature (zoom, focus, iris)
Focus:	Automatic with manual override
Sensitivity	
EIA:	.1 lux at f1.4, AGC gain 26.5 dB, signal level 40 IRE, without IR cut filter
CCIR:	.1 lux at f1.4, AGC gain 29.5 dB, signal level 300 mV, without IR cut filter
Signal Process:	DSP-3R
Sync System:	AC line lock, phase adjustable via remote control*
Shutter Speed:	Automatic (electronic iris)/manual
EIA:	1/60-1/30,000
CCIR:	1/50-1/30,000
Iris Control:	Automatic with manual override*
Gain Control:	Automatic with manual override*
Video Output	
EIA:	.714V ± .07V (100 IRE ± 10 IRE)
CCIR:	.7V ± .07V
Signal to Noise Ratio:	>46 dB

\* Manual control of camera setup functions can be done with CM6700, CM8500, CM9500, CM9760 and MPT9500 controllers, but not with CM7500, MPT9000 or KBD9000 controllers.

*(Design and product specifications subject to change without notice.)*

## REGULATORY NOTICES

Note: This equipment has been tested and found to comply with the limits of a Class A digital device, pursuant to part 15 of the FCC rules. These limits are designed to provide reasonable protection against harmful interference when the equipment is operated in a commercial environment. This equipment generates, uses, and can radiate radio frequency energy and, if not installed and used in accordance with the instruction manual, may cause harmful interference to radio communications. Operation of this equipment in a residential area is likely to cause harmful interference in which case the user will be required to correct the interference at his own expense.

## WARRANTY AND RETURN INFORMATION

### WARRANTY

Pelco will repair or replace, without charge, any merchandise proved defective in material or workmanship for a period of one year after the date of shipment. Exceptions to this warranty are as noted below:

- Three years on Genex™ Series (multiplexers, server, and keyboard).
- Two years on all standard motorized and fixed focal length lenses.
- Two years on Esprit™, Legacy®, Intercept®, PV1000 Series, CM6700/CM8500/CM9500/CM9750/CM9760 Matrix, Spectra®, DF5 Series and DF8 Fixed Dome products.
- Two years on WW5700 series window wiper (excluding wiper blades).
- Two years on cameras.
- Six months on all pan and tilts, scanners or preset lenses used in continuous motion applications (that is, preset scan, tour and auto scan modes).

Pelco will warrant all replacement parts and repairs for 90 days from the date of Pelco shipment. All goods requiring warranty repair shall be sent freight prepaid to Pelco, Clovis, California. Repairs made necessary by reason of misuse, alteration, normal wear, or accident are not covered under this warranty.

Pelco assumes no risk and shall be subject to no liability for damages or loss resulting from the specific use or application made of the Products. Pelco's liability for any claim, whether based on breach of contract, negligence, infringement of any rights of any party or product liability, relating to the Products shall not exceed the price paid by the Dealer to Pelco for such Products. In no event will Pelco be liable for any special, incidental or consequential damages (including loss of use, loss of profit and claims of third parties) however caused, whether by the negligence of Pelco or otherwise.

The above warranty provides the Dealer with specific legal rights. The Dealer may also have additional rights, which are subject to variation from state to state.

If a warranty repair is required, the Dealer must contact Pelco at (800) 289-9100 or (559) 292-1981 to obtain a Repair Authorization number (RA), and provide the following information:

1. Model and serial number
2. Date of shipment, P.O. number, Sales Order number, or Pelco invoice number
3. Details of the defect or problem

If there is a dispute regarding the warranty of a product which does not fall under the warranty conditions stated above, please include a written explanation with the product when returned.

Ship freight prepaid to: Pelco  
300 West Pontiac Way  
Clovis, CA 93612-5699

Method of return shipment shall be the same or equal to the method by which the item was received by Pelco.

### RETURNS

In order to expedite parts returned to the factory for repair or credit, please call the factory at (800) 289-9100 or (559) 292-1981 to obtain an authorization number (CA number if returned for credit, and RA number if returned for repair). Goods returned for repair or credit should be clearly identified with the assigned CA/RA number and freight should be prepaid. All merchandise returned for credit may be subject to a 20% restocking and refurbishing charge.

Ship freight prepaid to: Pelco  
300 West Pontiac Way  
Clovis, CA 93612-5699

## REVISION HISTORY

Manual #	Date	Comments
C1487M	7/98	Original version.
C1487M-A	11/98	Revised the manual to incorporate Spectra Lite™ material. Added material on CCIR and EIA monochrome cameras, and PAL color camera. Revised material in Section 5.11.21.2, Programming Limit Stops. Revised Section 6.0, Troubleshooting. Changed the fixed-speed controller rate in Section 8.0, Specifications.
C1487M-B	2/99	Changed Spectra Lite™ model numbers, and added comments that the line sync feature is not functional for the DD5T-C model of Spectra Lite™. Changed power specifications for indoor models from 25 vA to 30 vA and for outdoor models from 90 vA to 75 vA. Revised maximum temperature operating ranges. Revised color camera specifications.
C1487M-C	3/99	Changed auto iris material to include Spectra Lite™ as well as Spectra II™.
	7/99	Added a note relating to running patterns when an alarm activates. Changed the preset tilt speed from 100 to 200 degrees/second. Added model number and specifications for Spectra Lite™ PAL camera. Revised manual to new format.